

FLOW-BUS

MULTI-BUS Hook-up diagram

FLOW-BUS connection

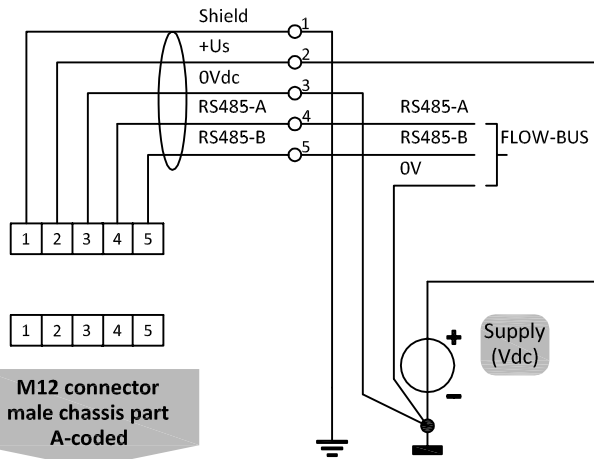

Types

IN-FLOW / IN-PRESS / LIQUI-FLOW

Model key explanation

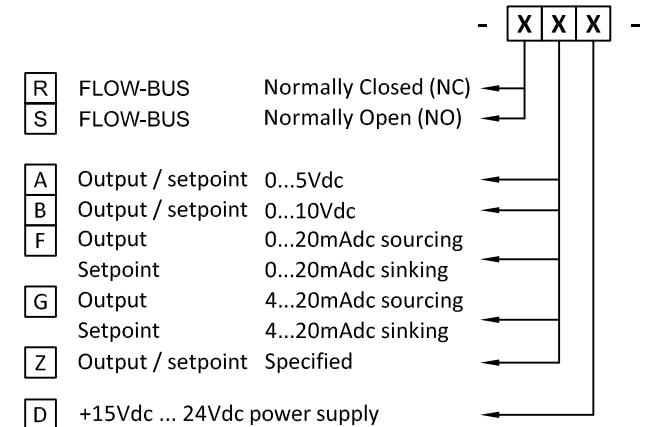

M12 connector male chassis part A-coded

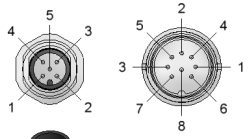

8 DIN connector chassis part male

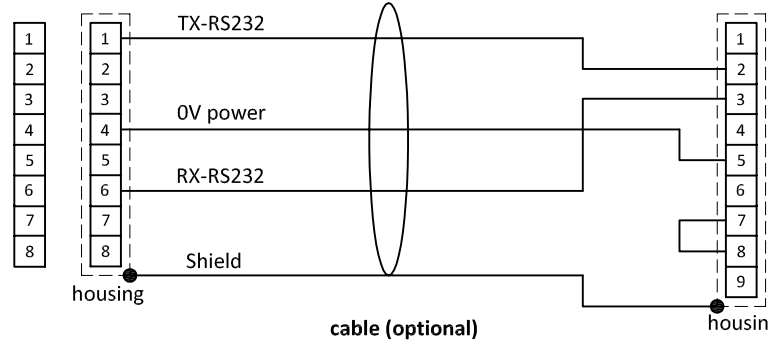
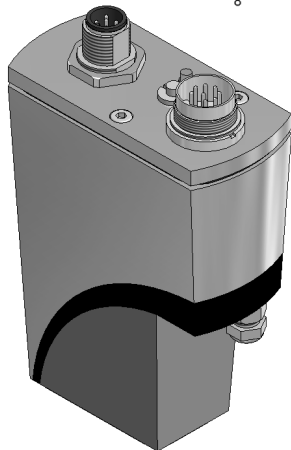

8 DIN connector chassis part male

8 DIN connector cable part female

RS232 COM -port 9 pin D-Sub connector chassis part male

Note:
When using a field bus or RS232, it is not possible to operate the instrument by using the setpoint signal of the analog 8 DIN connector without changing the value of parameter "control mode".
See doc.nr. 9.17.023 for more details

Note:
Do not connect an external valve to instruments, set as MFM or EPM

Note:
Powering a single instrument is possible by the 8 DIN connector.
Please consult 9.16.051 for a connection diagram.