

# PROFIBUS-DP<sup>®</sup>

## MULTI-BUS Hook-up diagram

### PROFIBUS connection

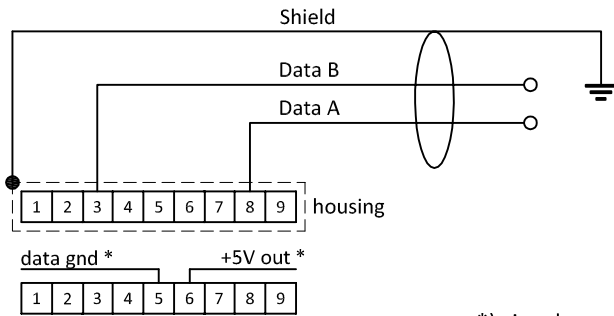

9 pin D-Sub connector chassis part female

\*) signals are for termination purpose only.

### RS232 connection

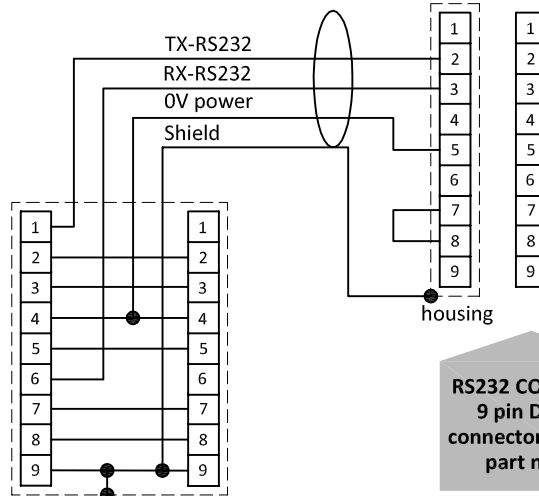

T-adaptor cable 7.03.366

RS232 COM-port 9 pin D-Sub connector chassis part male

### Types

EL-FLOW / EL-PRESS /  $\mu$ -FLOW/ LIQUI-FLOW

### Model key explanation

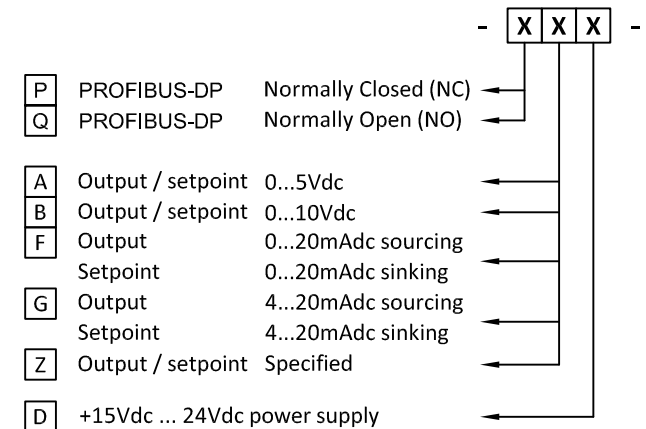

9 pin D-Sub connector chassis part female

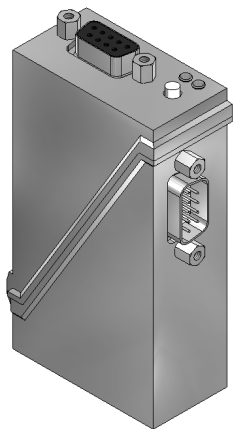
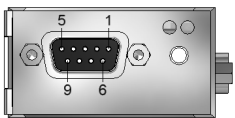

9 pin D-Sub connector chassis part male

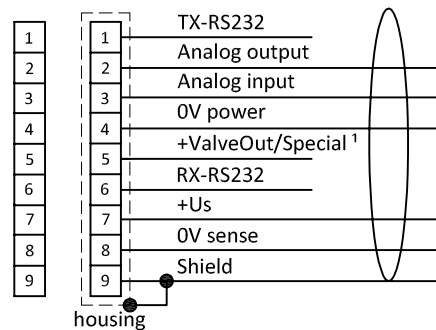
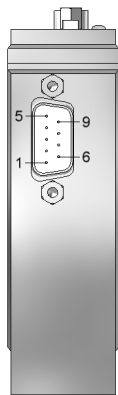

9 pin D-Sub connector chassis part male

9 pin D-Sub connector cable part female

Note: Do not connect an external valve to instruments, set as MFM or EPM.

Note: \*) for MBC3 type instruments: +Valve out is 0...10Vdc 1mA

Note: 0V power (pin 4) and 0V sense (pin 8) should be separately connected to the 0V terminal at the power supply.

Analog operated 0...5 or 0...10Vdc

Note: When using a field bus or RS232, it is not possible to operate the instrument by using the setpoint signal of the analog D-sub connector without changing the value of parameter "control mode". See doc.nr. 9.17.023 for more details

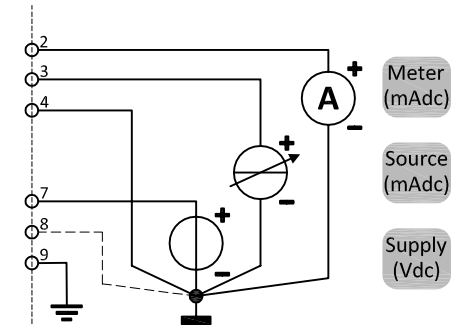

Note: In analog mode with 'mA signals' Pin 8 (0V sense) does not need to be connected. The instrument's operation will not be effected in case Pin 8 is already hooked-up

Analog operated 0...20 or 4...20mA dc