



Instruction manual



**Mass Flow / Pressure
meters and controllers
for gases and liquids**

Doc. no.: 9.17.001N Date: 27-06-2011



ATTENTION

Please read this instruction manual carefully before installing and operating the instrument.
Not following the guidelines could result in personal injury and/or damage to the equipment.

Even though care has been taken in the preparation and publication of the contents of this manual, we do not assume legal or other liability for any inaccuracy, mistake, mis-statement or any other error of whatsoever nature contained herein. The material in this manual is for information purposes only, and is subject to change without notice.

Bronkhorst High-Tech B.V.
June 2011

Warranty

The products of Bronkhorst High-Tech B.V. are warranted against defects in material and workmanship for a period of three years from the date of shipment, provided they are used in accordance with the ordering specifications and the instructions in this manual and that they are not subjected to abuse, physical damage or contamination. Products that do not operated properly during this period may be repaired or replaced at no charge. Repairs are normally warranted for one year or the balance of the original warranty, whichever is the longer.

See also paragraph 9 of the Conditions of Sales.

The warranty includes all initial and latent defects, random failures, and indeterminable internal causes.

It excludes failures and damage caused by the customer, such as contamination, improper electrical hook-up, dropping etc.

Re-conditioning of products primarily returned for warranty service that is partly or wholly judged non-warranty may be charged for.

Bronkhorst High-Tech B.V. prepays outgoing freight charges when any part of the service is performed under warranty, unless otherwise agreed upon beforehand.

However, if the product has been returned collect to Bronkhorst High-Tech B.V., these costs are added to the repair invoice. Import and/or export charges, foreign shipping methods/carriers are paid for by the customer.

Short-Form Operation Instruction

Before installing your Mass Flow or Pressure Meter/ Controller it is important to read the attached label and check:

- flow/pressure rate
- fluid to be metered
- up and downstream pressures
- input/output signal

Check the red-coloured sticker and make sure the test pressure is in agreement with normal safety factors for your application.

Check if the piping system is clean. For absolute cleanliness always install filters to assure a clean liquid stream or a moisture and oil-free gas stream.

Install the Meter/Controller in the line and tighten the fittings according to the instructions of the supplier of the fittings. Choose the mounting position according to the directions given in this manual.

Check the system for leaks before applying fluid pressure

Electrical connections must be made with a standard cable or according to the hook - up diagram in the back of this manual.

Apply power to the instrument and allow for approx. 30 minutes to warm-up and stabilize. This may be done with or without fluid pressure, applied to the system.

Your instrument is now ready for operation.

TABLE OF CONTENTS

1. Introduction

1.1	General description	page 7
1.1.1	Gas flow	page 7
1.1.2	Liquid flow	page 7
1.1.3	Pressure	page 7
1.2	Housings	page 7
1.2.1	EL-FLOW, EL-PRESS (Euro-style)	page 7
1.2.2	Liquid flow meters / controllers	page 7
1.3	Valves	page 8
1.3.1	Laboratory style	page 8
1.3.2	Industrial style.....	page 8
1.4	Sensor principles	page 8
1.4.1	Gasflow sensors	page 8
1.4.2	Liquid flow sensors	page 8
1.4.3	Pressure sensor	page 9
1.5	Valve principles	page 9
1.5.1	Solenoid valve	page 9
1.5.2	Vary-P valve	page 9
1.5.3	Pilot operated valve	page 10
1.5.4	Bellows valve	page 10
1.6	Sensors and laminar flow devices	page 10
1.7	Electronics	page 11
1.8	Conversion factors	page 12
1.8.1	Gas conversion factors	page 12
1.8.2	Liquid conversion factors	page 14
1.8.3	Software for conversion factor calculation	page 14

2. Installation

2.1	Receipt of equipment	page 15
2.2	Return shipment	page 15
2.3	Service	page 15
2.4	Mounting	page 15
2.5	In-line filter	page 16
2.6	Fluid connections	page 16
2.7	Piping	page 16
2.8	Electrical connections	page 17
2.9	Caution	page 17
2.10	Supply pressure	page 17
2.11	System purging	page 17
2.12	Seals	page 17
2.13	Equipment storage	page 17
2.14	Electromagnetical compatibility	page 18
2.14.1	Conditions for compliance with EMC requirements	page 18

3. Operation

3.1	General	page 20
3.2	Power and warm-up	page 20
3.3	Zeroing	page 20
3.4	Start-up	page 20
3.5	Operating conditions	page 20
3.6	Instrument performance	page 21
3.6.1	Sensors	page 21
3.6.2	Controllers	page 21

4. Maintenance

4.1	General	page 22
4.2	Gas flow sensor	page 22
4.3	Liquid flow sensor	page 22
4.4	Pressure sensor	page 22
4.5	Controllers	page 22
4.6	Control valves	page 22
4.6.1	Solenoid valves	page 22
4.6.2	Vary-P valve	page 23
4.6.3	Pilot operated valve	page 23
4.6.4	Bellows valve	page 23
4.7	K _v -value calculation	page 24
4.7.1	For gases	page 24
4.7.2	For liquids	page 24
4.8	Maximum pressure drop	page 25
4.9	Calibration procedure	page 26

5. Troubleshooting

5.1	General	page 27
5.2	Troubleshooting summary	page 27

Appendices

1	Gasconversion table
2	Enclosures

1 Introduction

1.1 General description

1.1.1 Gas flow

The Bronkhorst High-Tech B.V. series mass flow meter for gases is an accurate device for measuring gas flows up to 700 bar depending on body rating, virtually independent of pressure and temperature changes. The system can be completed with a control valve and flexible readout to measure and control gas flows from 3 ml_n/min up to several thousand m³_n/h, depending on the specific type of instrument. For a limited flow range a metal sealed model is available.

1.1.2 Liquid flow

The Bronkhorst High-Tech B.V. mass flow meter for liquids is an accurate device for measuring liquid flows up to 400 bar, virtually independent of pressure and temperature changes. The system can be completed with a control valve to measure and control liquid flows.

1.1.3 Pressure

The Bronkhorst High-Tech B.V. pressure meter measures pressures from 100 mbar up to 400 bar depending on body rating, either absolute pressure or gauge pressure and in the range 0 to 15 bar differential pressure too. The pressure controller controls pressure with a very high accuracy and repeatability. The controller is available in forward control (P-600 series) and backward control (P-700 series). The flow going through the pressure controller depends on up and downstream pressures, the orifice diameter of the valve and kind of fluid.

1.2 Housings

Each instrument housing style incorporates several provisions to comply with EMC requirements.

1.2.1 EL-FLOW[®] , EL-PRESS (Euro-style)

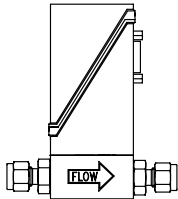

The p.c.board is placed in a metalized plastic cover. For electrical connection the instrument has a male 9-pin miniature sub-D connector. These instruments are suited for indoor (dry) applications, like laboratories and in well protected (OEM) housings.

1.2.2 Liquid flow meter / controller

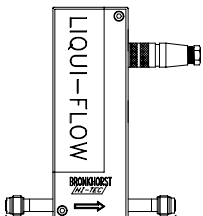

The LIQUI-FLOW[®] models for up to 1000 g/h. This is a fully aluminium casted instrument, which means that the instrument is formed by the housing. This model has an IP-65 ingress protection class. For electrical connection a round male 8-pin DIN connector is incorporated in the design. The instrument is suited for light industrial (outdoor) use.

1.3 Valves

Two solenoid housing models can be distinguished. The basic mechanical design of both models is the same. Valves are used as separate units, or integrated with a meter to form a complete control unit. The solenoid versions are:

1.3.1 Laboratory style

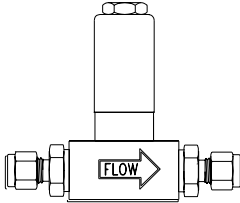

The solenoids of these valves have an IP-50 ingress protection class. This means that the valves are suited for indoor (dry) use.

1.3.2 Industrial style

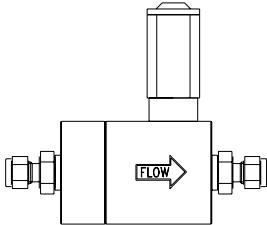

The solenoids of these valves have an IP-65 ingress protection class. This means that they are suited for light industrial (outdoor) use.

1.4 Sensor principles

1.4.1 Gas flow sensors

All gasflow sensors operate according to the same principle. They are operating on a principle of heat transfer by sensing the delta-T along a heated section of a capillary tube. Part of the total flow is forced through the capillary by means of a laminar flow device in the main stream generating a delta-p. The design of the laminar flow device is such that flow conditions in both the capillary and laminar flow device are comparable, thereby resulting in proportional flow rates through the meter. The delta-T sensed by the upstream and downstream temperature sensors on the capillary depends on the amount of heat absorbed by the gas flow.

The transfer function between gas mass flow and signal can be described by the equation:

$$V_{\text{signal}} = K \cdot c_p \cdot \Phi_m$$

V_{signal} = output signal

c_p = specific heat

K = constant factor

Φ_m = mass flow

The temperature sensors are part of a bridge circuit and the imbalance is linearised and amplified to the desired signal level.

1.4.2 Liquid flow sensor

- The LIQUI-FLOW mass flow meter for flow rates up to about 1000 g/h is basically a tube of stainless steel without any built-in obstructions, internal diameter approx 1 mm. This tube is part of a completely casted aluminium housing. An important part of the instrument is formed by two legs of tubing; an upstream section and a downstream section. On these two legs the heater/sensor arrangement of patented design is placed. The sensor measures the

temperature difference between the upstream and the downstream leg of the measuring tube by means of a thermopile. The simplified transfer function can be described according to the following equation:

$$V_{\text{signal}} = K \cdot c_p \cdot \Phi_m$$

V_{signal} = output signal
 K = constant factor
 c_p = specific heat
 Φ_m = mass flow

1.4.3 Pressure sensor

The EL-PRESS pressure sensor is formed by a piezoresistive bridge on the surface of a silicon crystal. The sensor is mounted in a stainless steel construction and separated from the fluid by a thin metal membrane. The chamber around the sensor is filled with oil to couple the pressure from the fluid to the sensor.

1.5 Valve principles

Control valves are not designed to provide positive shut-off, although some models have excellent capabilities for this purpose.

It is recommended to install a separate shut-off valve in the line if so required. Also pressure surges, as may occur during system pressurisation must be avoided. The following models can be distinguished:

1.5.1 Solenoid valve

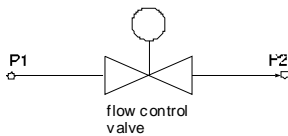

This is considered to be the standard (direct operated) control valve. In general it is a normally closed solenoid valve. The plunger is lifted by the force of the magnetic field of the coil. The orifice under the plunger is removable for optimising the orifice diameter. Also a normally opened solenoid valve is available.

1.5.2 Vary-P valve

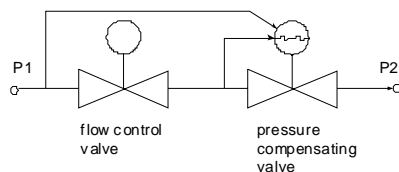

For process conditions where up- and downstream pressures vary much, a special type of valve, VARY-P has been designed. This valve consists of two valves, a solenoid operated control valve and a fixed adjusted pressure compensation valve.

1.5.3 Pilot operated valve

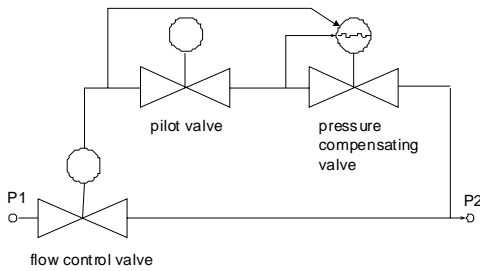

For high flow rates the pilot operated valve has been designed. A solenoid driven control valve controls the pressure difference across a piston, which lifts the main plunger.

1.5.4 Bellows valve

This valve type is a direct driven, low power, solenoid operated control valve. A special design, incorporating a metal bellows allows for a relatively large orifice opening to be controlled. The design is suited for low pressure or vacuum applications.

1.6 Sensors and laminar flow devices

Flow devices are used to determine the total flow rate of a gas flow meter or controller.

Mind that liquid flow sensors and pressure sensors do not require a flow device.

Depending on the application the flow sensors have different removable capillaries, requiring a different laminar flow device.

Furthermore for flow rates higher than 1250 l_n/min the main laminar flow device is used in combination with a capillary / flow device arrangement in order to compensate for the non ideal transfer function of the main flow device.

In general 3 types of capillary tubes are available:

- Small bore (C-type)

The following notes apply to this type of sensor:

- These sensors have a pressure drop of approx. 35 mbar
- The laminar flow device consists of a stack of discs with precision etched flow channels. Each flow channel represents approx. 10 ml_n/min airflow at 35 mbar delta-P.
- In general instruments with these sensors may be mounted horizontal, as well as in a vertical position, at low operating pressures. At high pressures (>10 bar) the instruments should be mounted in a horizontal position.

- Large bore (D-type)

To this type of sensor the following remarks apply:

- These sensors are preferably used for reactive gases and at low pressure applications.
- The pressure drop is less than 0.5 mbar.
- The laminar flow device forms together with the main channel an annular channel. The dimensions of this annular channel determine the flow capacity of the instrument.
- The instrument must always be mounted in a horizontal position.

- Medium bore (E-type)

This sensor is used in the "EL-FLOW series" and is used for increasing the flowrange of the "low deltaP series". The same remarks as the D-type apply to this sensor, only:

- The pressure drop is approx. 2.5 mbar .

1.7 Electronics

Each electronic housing is designed to provide RFI and EMI protection.

The p.c.boards designed by BRONKHORST HIGH-TECH B.V. are mainly provided with surface mounted devices (SMD).

Each electronic p.c.board is set for one of the following output (and corresponding input) signals:

Signal code	output (sensor) signal	input (setpoint) signal
A	0...5 Vdc	0...5 Vdc
B	0...10 Vdc	0...10 Vdc
F	0...20 mA (sourcing)	0...20 mA (sinking)
G	4...20 mA (sourcing)	4...20 mA (sinking)
K	0...5 Vdc (cable compensation)	n.a.
L	0...10 Vdc (cable compensation)	n.a.

For meters only

For meters only

Current output signals

Sinking

Sourcing

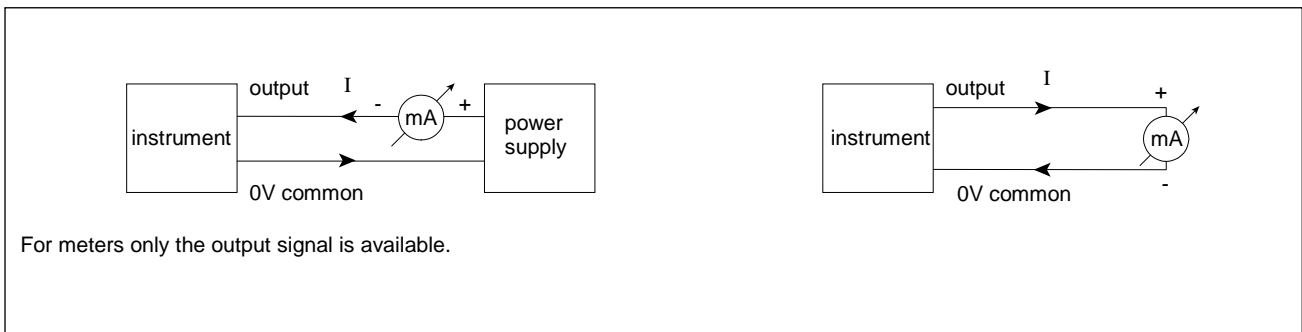

1.8 Conversion factors

1.8.1 Gas conversion factors

The general formula for determining the relationship between signal and mass flow is:

$$V_{\text{signal}} = K \cdot c_p \cdot \Phi_m = K \cdot c_p \cdot \rho \cdot \Phi_v$$

in which:

V_{signal}	= output signal
K	= constant
ρ	= density
c_p	= specific heat
Φ_m	= mass flow
Φ_v	= volume flow

As soon as the c_p value and density of the gas to be metered change, the signal must be corrected. The conversion factor C is:

$$C = \frac{c_{p1} \cdot \rho_1}{c_{p2} \cdot \rho_2}$$

in which:

c_p	= specific heat
ρ_n	= density at normal conditions

- (1) gas calibrated
(2) gas to be measured

Note:

The c_p value used for the calculation of the conversion factor must be taken at a temperature approx. 50°C. higher than the required temperature.

This factor is called c_p cal.

The conversion factors for commonly used gases related to N_2 at normal conditions are stated in the Gas Conversion Table in the appendix 1.

Example:

Meter calibrated on N_2 (200 ml_n/min).

Gas flow passing the meter is CO_2 .

Output signal reads 80.0%.

$$\text{Actual } CO_2 \text{ flow} = 80.0 \cdot \frac{0.74}{1.00} = 59.2\%$$

$$\text{so } \frac{59.2}{100} \cdot 200 = 118.4 \text{ ml}_n/\text{min}$$

* **n** means **normal conditions**

At normal conditions volumes are converted to a temperature of 0°C and pressure of 1 atm or 1013,25 mbar. (760 Torr)

Note:

Best accuracy is always achieved by performing calibration under operating conditions. Should this not be possible or practical, then the use of a theoretical conversion factor is a means to determine the flow rate of the instrument on the gas to be metered, however, it will introduce inaccuracies.

The approximate accuracy of the conversion factors listed is:

typical for conversion factors; > 1 **2% x factor**
 < 1 **2% / factor**

However, as the accuracy of the factor also depends on viscosity, pressure and temperature, special attention should be taken for gases in the gas/liquid state where specific heat, density and viscosity can vary tremendously. Apply to factory for more detailed information.

For gas mixtures a good approach is the following simplified equation:

$$\frac{1}{C_{\text{mix}}} = \frac{V_1}{C_1} + \frac{V_2}{C_2} + \dots + \frac{V_n}{C_n}$$

C_{mix} = Conversion factor for gas mixture
 C_n = Conversion factor for gas n
 V_n = Volumetric part of gas n in the mixture

Example Gas mixture contains:

- (1) 10% N₂ C1 = 1,00
- (2) 30% Ar C2 = 1,40
- (3) 50% CH₄ C3 = 0,76
- (4) 10% He C4 = 1,41

$$\frac{1}{C_{\text{mix}}} = \frac{0,10}{1,00} + \frac{0,30}{1,40} + \frac{0,50}{0,76} + \frac{0,10}{1,41} = 1,043$$

$C_{\text{mix}} = 0,959$

When the original meter has been calibrated on 500 ml_r/min N₂, 100% means:

$$500 \cdot \frac{0,959}{1,00} = 480 \text{ ml}_r/\text{min mixture.}$$

When the original meter has been calibrated on 500 ml_r/min Argon, then 100% means:

$$500 \cdot \frac{0,959}{1,40} = 343 \text{ ml}_r/\text{min gas mixture.}$$

1.8.2 Liquid conversion factors

The general formula for determining the relationship between signal and mass flow reads:

$$V_{\text{signal}} = k \cdot c_p \cdot \Phi_m$$

in which:

- V_{signal} = output signal
- k = calibration constant
- c_p = heat capacity at constant pressure of the fluid
- Φ_m = mass flow

A conversion factor must be used if the liquid flow meter is not used on the calibrated liquid. This conversion factor reads:

$$\Phi_{m_2} = C_f \cdot \Phi_{m_1}$$

$$C_f = \frac{c_{p1}}{c_{p2}}$$

in which:

- c_{p1} = heat capacity of the calibration liquid
- c_{p2} = heat capacity of the new liquid

For application of this formula consult Bronkhorst High-Tech B.V.

1.8.3 Software for conversion factor calculation

Bronkhorst High-Tech B.V. gathered the physical properties of over 600 fluids in a database called FLUIDAT®.

Application software, such as FLUIDAT® on the Net (FOTN), enable the user to calculate accurate conversion factors, not only at 20°C/1 atm (as shown in the conversion table, App.1) but at any temperature/pressure combination.

Apply to your distributor for more details of this software.

2 Installation

2.1 Receipt of equipment

Check the outside packing box for damage incurred during shipment. Should the packing box be damaged, then the local carrier must be notified at once regarding his liability, if so required. At the same time a report should be submitted to:

BRONKHORST HIGH-TECH B.V.
RUURLO HOLLAND

If applicable, otherwise contact your distributor.

Remove the envelope containing the packing list; carefully remove the equipment from the packing box.

Do not discard spare or replacement parts with the packing material and inspect the contents for damaged or missing parts.

2.2 Return shipment

When returning material, always describe the problem and if possible the work to be done, in a covering letter.

It is absolutely required to notify the factory if toxic or dangerous fluids have been metered with the instrument!

This to enable the factory to take sufficient precautionary measures to safeguard the staff in their repair department. Take proper care of packing, if possible use the original packing box; seal instrument in plastic etc.

Contaminated instruments must be dispatched with a completely filled in 'declaration on contamination form'.

Contaminated instruments without this declaration will not be accepted.

Note:

If the instruments have been used with toxic or dangerous fluids the customer should pre-clean the instrument.

Important:

Clearly note, on top of the package, the customer clearance number of Bronkhorst High-Tech B.V., namely:

NL801989978B01

If applicable, otherwise contact your distributor for local arrangements.

2.3 Service

If the equipment is not properly serviced, serious personal injury and/or damage to the equipment could be the result. It is therefore important that trained and qualified service personnel perform servicing. Bronkhorst High-Tech B.V. has a trained staff of servicemen available.

2.4 Mounting

The mounting position depends on the type of instrument. For flowmeters the preferred position is horizontal, and at high pressures all meters should be mounted in this position (exception: COMBI-FLOW series to be mounted vertically). Avoid installation in close proximity of mechanic vibration and/or heat sources.

2.5 In-line filter

Although fluids to be measured should be absolutely free of dirt, oil, moisture and other particles, it is recommended to install an in-line filter upstream of the flowmeter / controller, and if backflow can occur, a downstream filter is recommended too. Be aware of the pressure drop caused by the filter. On the inlet of some instruments a screen is placed to prevent foreign matter from entering the instrument and to maintain a good flowpattern. This device **cannot** be seen as a filter element. Contact your distributor for further information.

2.6 Fluid connections

Bronkhorst High-Tech B.V. meters / controllers are equipped with compression or face-seal-fittings. For some instruments these fittings are orbitally welded to the body. For leak tight installation of compression type fittings be sure that the tube is inserted to the shoulder in the fitting body and that no dirt or dust is present on tube, ferrules or fittings. Tighten the nut fingertight; while holding the instrument, then tighten the nut 1 turn. If applicable follow the guidelines of the supplier of the fittings. Special types of fittings are available on request. While tightening fittings, do not apply excessive force, in order to avoid damaging in/output thread or other sensitive parts of your instruments.

* **Note:** Always check your system for leaks, before applying fluid pressure. Especially if toxic, explosive or other dangerous fluids are used.

2.7 Piping

BE SURE THAT PIPING IS ABSOLUTELY CLEAN!

DO NOT install small diameter piping on high flowrates, because the inlet jetflow will affect the accuracy.

DO NOT mount abrupt angles direct on in- and outlet, especially not on high flowrates. We recommend at least 10 pipe diameters distance between the angle and the instrument.

DO NOT mount pressure regulators direct on the inlet of gas flow meters/controllers, but allow some meters of piping (at least 25 D). Special attention should be taken at high flow rates with flow controllers. An up- and downstream buffer is needed with a volume calculated according to the following formula:

$$V \geq \frac{0,15 d^2}{\sqrt{\rho}}$$

in which:

V = Volume in litres

d = orifice diameter in mm

ρ = density at normal conditions

$d = 7,6 \sqrt{k_v}$

Example:

Flow controller at 500 l_r/min Air and orifice diameter d = 4 mm, needs for stable control a buffer volume of:

$$V \geq 0,15 \cdot 4^2 : \sqrt{1,29} = 2,1 \text{ litres}$$

Also the capacity of the pressure regulator should be at least 2 times the flow controller, so in this case $2 \cdot 500 = 1,000$ l_r/min.

2.8 Electrical connections

Bronkhorst High-Tech B.V. recommends to use their standard cables. These cables have the right connectors and if loose ends are used, these will be marked to prevent wrong connection. Hook-up diagrams are enclosed in the back of this manual.

2.9 Caution

Each meter/controller is pressure tested to at least 1.5 times the working pressure of the process conditions stipulated by the customer, with a minimum of 8 bar.

For pressure meter/controllers. The test pressure depends on the range of the pressure transducer.

In general

2	x F.S. value for ranges 1 and 2 bar
1.5	x F.S. value for ranges up to 200 bar
1.25	x F.S. value for ranges up to 400 bar

The tested pressure is stated on the flow meter/controller with a RED COLOURED sticker. Check test pressure before installing in the line.

If the sticker is **not** available or the test pressure is incorrect, the instrument should **not** be mounted in the process line and be returned to the factory.

Each instrument is helium leak tested to at least $2 \cdot 10^{-9}$ mbar l/s Helium.

2.10 Supply pressure

Do not apply pressure until electrical connections are made. When applying pressure to the system, take care to avoid pressure shocks in the system and increase pressure gradually, especially on high pressure units incorporating a piston operated control valve.

2.11 System purging

If explosive gases are to be used, purge the process with inert dry gas like Nitrogen, Argon etc. for at least 30 minutes.

In systems with corrosive or reactive fluids, purging with an inert gas is absolutely necessary, because if the tubing has been exposed to air, introducing these fluids will tend to clog up or corrode the system due to a chemical reaction with oxygen or moist air.

Complete purging is also required to remove such fluids from the system before exposing the system to air. It is preferred not to expose the system to air, when working with these corrosive fluids.

2.12 Seals

Bronkhorst High-Tech B.V. has gathered a material compatibility chart from a number of sources believed to be reliable.

However, it is a general guide only. Operating conditions may substantially change the accuracy of this guide. Therefore there is no liability for damages accruing from the use of this guide.

The customers' application will demand its own specific design or test evaluation for optimum reliability. So check if the seals like O-rings, plunger and packing gland of capillary are correct for the process.

2.13 Equipment storage

The equipment should be stored in its original packing in a cupboard warehouse or similar. Care should be taken not to subject the equipment to excessive temperatures or humidity.

2.14 Electromagnetic compatibility

2.14.1 Conditions for compliance with EMC requirements

All instruments described in this manual carry the CE-mark.

Therefore they have to comply with the EMC requirements as are valid for these instruments.

However compliance with the EMC requirements is not possible without the use of proper cables and connector/gland assemblies.

For good results Bronkhorst High-Tech B.V. can provide standard cables. Otherwise follow the guidelines as stated below.

1. D-Connector assembly

Fold the shield of the cable back over the cable (the shield must be around the cable).

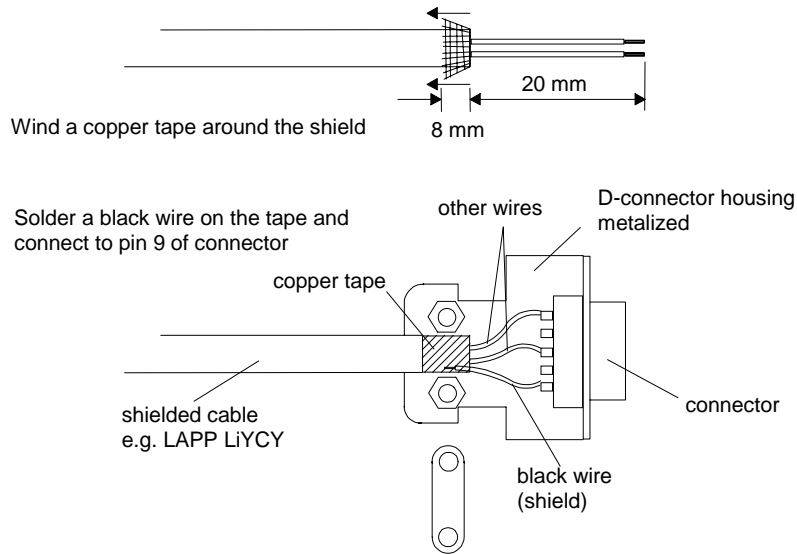

2. Cable gland assembly

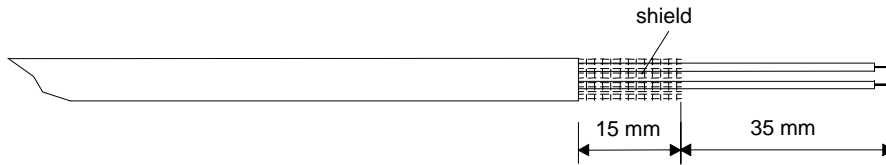

Fold the shield of the cable back over the cable (shield must be around the cable).

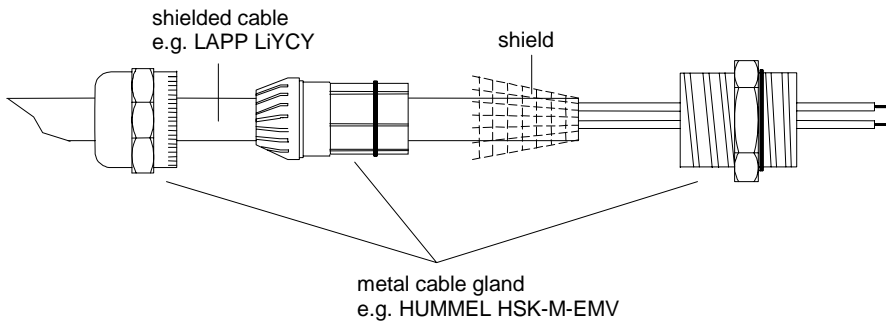

Mount the metal PG cable gland as shown in the drawing above

3. Connector LIQUI-FLOW®

8 DIN CONNECTOR AMPHENOL

C091 31D008 200 2

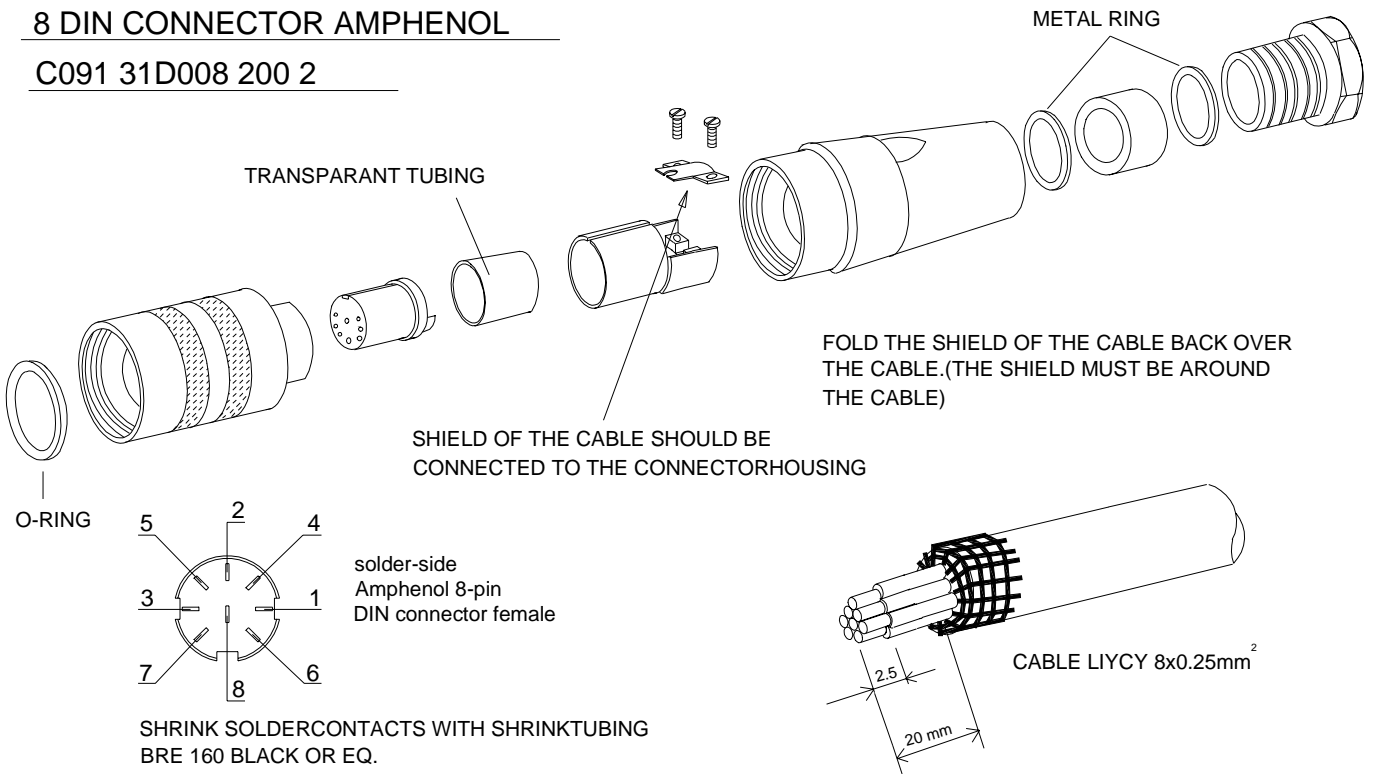

8 DIN CONNECTOR BINDER

SERIE 423 99.5672.19.08

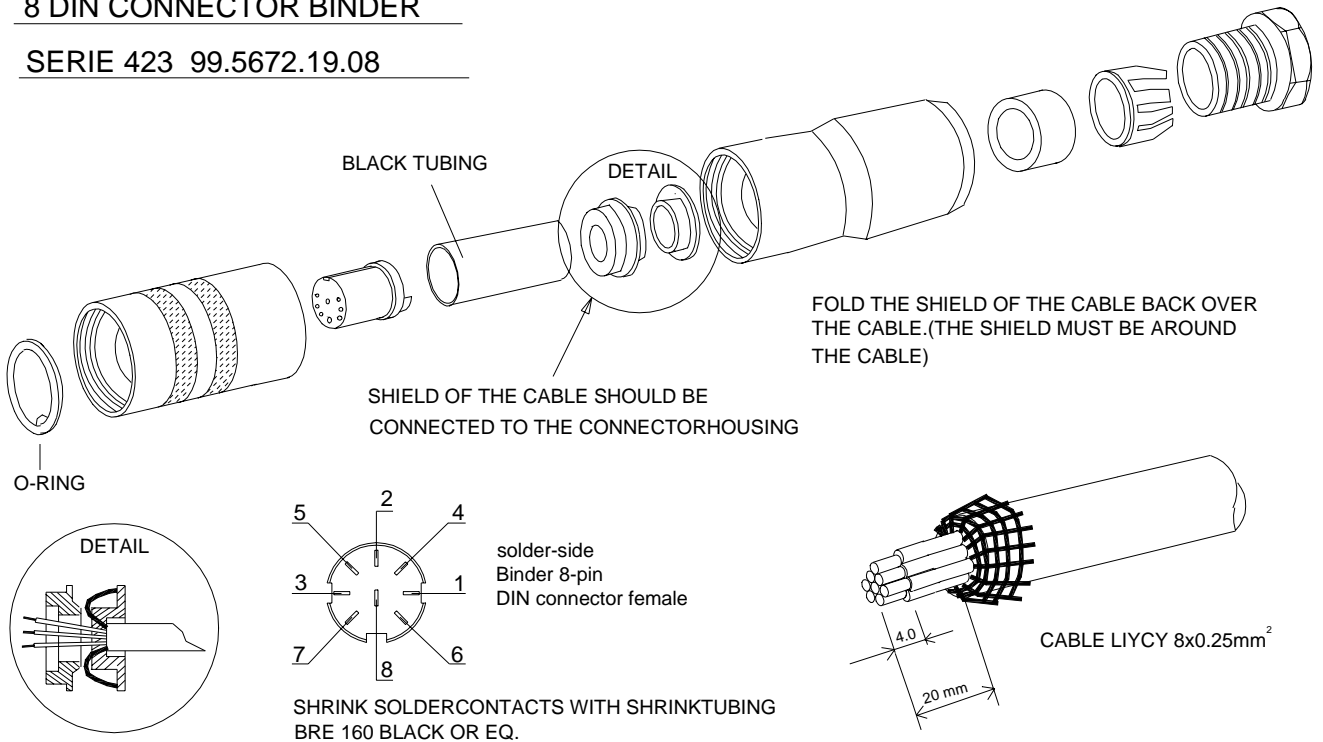

Note:

When connecting the system to other devices (e.g. to PLC), be sure that the integrity of the shielding is not affected. Do not use unshielded wire terminals.

3 Operation

3.1 General

The Bronkhorst High-Tech instruments are designed in such a way that they will meet user process requirements in the best possible way.

Flow / pressure meters and controllers are powered from a dc power source. When providing your own power supply be sure that voltage and current rating are according to the specifications of the instrument(s) and furthermore that the source is capable of delivering enough energy to the instrument(s).

Cable wire diameters should be sufficient to carry the supply current and voltage losses must be kept as low as possible. When in doubt: consult factory.

3.2 Power and warm-up

Before switching on power check if all connections have been made according to the hook-up diagram, which belongs to the instrument.

It is recommended to turn on power before applying pressure on the instrument and to switch off power after removing pressure.

Check fluid connections and make sure there is no leakage. If needed purge the system with a proper fluid. For a gas instrument only purging with gases is allowed. Liquid instruments may be purged with either a gas or a liquid, whatever is needed for the purpose.

Turn on power and allow at least 30 minutes to warm up and stabilize. In cases where no electronics are involved (valves only) warming up is not needed.

During warm-up period, fluid pressure may either be on or off.

3.3 Zeroing

In general the zero point of each instrument is factory adjusted. If so required the zero point of the instrument may be re-adjusted.

Zero points must be adjusted to read approx. 0.2%. The circuit will cut off signals below zero to prevent negative zero drift. When adjustment is required, first make sure that there is a positive deviation, and then slowly adjust the readout to read approx. 0.2%. To be sure that there is no accidental flow or pressure level other than zero, adjustment is done best when the instrument is not part of a system.

3.4 Start-up

Turn on fluid supply gently. Avoid pressure shocks, and bring the instrument gradually up to the level of the actual operating conditions. Also switch off fluid supply gently. In case of liquid control be sure to remove all trapped gas bubbles from the system. The purge connection on top of the control valve can be used for this purpose.

3.5 Operating conditions

Each instrument has been calibrated and adjusted for customer process conditions.

Controllers or valves may not operate correctly, if process conditions vary too much, because of the restriction of the orifice in the valve.

For flowmeters performance and accuracy may be affected tremendously if physical fluid properties such as heat capacity and viscosity change due to changing process conditions.

3.6 Instrument performance

3.6.1 Sensors

Assuming that the transfer function of a system is an exponential shaped curve, the time constant is defined as follows:

time constant = time for the signal to reach 63.2 % of its final output value. Approx. five time constants is the time to reach the final value.

Each flow sensor has a time constant of 5...10 seconds, which can be electronically improved to approx. 1...3 seconds.

For gas flow meters factory standard adjustment is 3 seconds typical.

For liquid flow meters the actual response depends on model and flow rate.

Pressure sensors have a time constant of some milliseconds. However the actual response is determined by the pneumatic response of the system which the pressure meter is part of.

3.6.2 Controllers

The dynamic response of a controller is factory set. Standard settling time is defined as the time to reach the setpoint (and stay) within $\pm 2\%$ of the initial setpoint.

The control mode is factory set in such a way that after a step change, there will be little overshoot.

Note:

In pressure control systems the system widely determines the response behaviour of the control loop. During testing the customer system is simulated as closely as possible. In some cases however readjustment is needed for optimum performance under actual conditions.

4 Maintenance

4.1 General

No routine maintenance is required to be performed on the meters or controllers. Units may be flushed with clean, dry inert gas.

In case of severe contamination it may be required to clean the laminar flow device and the valve orifice separately.

4.2 Gas flow sensor

The gasflow sensor is constructed in such a way that for a change in range, the laminar flow element can be removed. It is not recommended for the user to disassemble the instrument other than for removing the laminar flow element for inspection, or range changing only. After replacing the laminar flow element it becomes necessary to recalibrate the flow meter. When doing so proceed according to a suitable calibration procedure. Depending on the model number laminar flow elements can be ordered separately.

4.3 Liquid flow sensor

The user cannot change the flow range of a liquid flow sensor. The sensor is an integral part of the instrument and cannot be removed from it. For occasional cleaning the instrument may be flushed with a cleaning fluid.

4.4 Pressure sensor

It is not recommended for the user to disassemble the pressure sensor, because the thin metal membrane is very delicate.

4.5 Controllers

All sensor types can be combined with a control valve to be operated together as a control loop. Controller systems are either available as separate units; a sensor and a control valve, or as an integrated unit. If applicable maintenance procedures are described under "control valves"

4.6 Control valves

Control valves cannot be used for shut-off and/or on-off applications. Pressure surges, as may occur during system pressurisation or deflation must be avoided.

4.6.1 Solenoid valves

These are considered to be the direct operated control and pilot valves. They may be disassembled in the field by the user for cleaning and servicing. The parts can be cleaned with a cleaning liquid, or in an ultrasonic bath.

To disassemble the valve proceed as follows:

- a) disconnect the instrument connector (not necessary with separate valve)
- b) remove the hex nut on top of the valve assembly
- c) lift the cover (coil) assembly
- d) unscrew the flange
- e) lift valve assembly carefully from the base
- f) unscrew set screw for the orifice and subsequently loosen the orifice and the orifice holder
- g) remove the plunger assembly

Clean parts and carefully re-assemble in reverse order. It is recommended to replace the O-rings prior to re-assembly.

After having re-assembled the control valve, it is recommended to check the control characteristics of the valve. This can best be done by using a separate variable 15 Vdc power supply source.

Proceed as follows:

- disconnect the valve leads and connect to supply source
- apply gas pressure as per working conditions
- apply power by gradually increasing voltage
- the valve should open at $7 \text{ Vdc} \pm 3 \text{ Vdc}$
- the fully opened position is reached at approx. $9 \text{ Vdc} \pm 1.5 \text{ Vdc}$.

In case the valve does not operate within the voltage levels stated, then it must be disassembled, and the orifice must be adjusted to the proper position.

Re-assemble valve and repeat procedure if required.

4.6.2 Vary-P valve

The vary-P valve is designed to cope with extremely varying process conditions on either upstream or downstream side of the valve or a combination of these. Δp can vary over a wide range. The basic control valve is a direct operated solenoid control valve.

The design has been patented.

For orifice selection and maintenance other than the pilot valve consult the factory.

4.6.3 Pilot operated valve

This control valve is an indirect control valve, consisting of a spring-loaded membrane/orifice system which is positioned by a solenoid operated direct control (pilot valve). The two devices are integrated in one block.

Basically follow the same procedures for dis-assembly as stipulated under "Solenoid valves"

For cleaning purposes it may be required to dis-assemble further, i.e. also remove the membrane assembly.

Note:

When pressure testing a system incorporating a pilot operated control valve, a special procedure must be followed in order to prevent damage to the valve. In such cases it is necessary to contact the factory prior to do this.

4.6.4 Bellows valve

These valves are suited for low pressure or vacuum applications. Preferably the user should not disassemble this model.

4.7 K_v -value calculation

This calculation method can be used to determine the K_v -value of the main orifice of a control valve.

4.7.1 For gases

Determine desired Δp across valve.

Δp must be at least 20% of supply pressure, or in closed loop systems, of total pressure difference in loop.

If Δp is 20-50% of supply pressure, use formula:

$$K_v = \frac{\Phi_{vn}}{514} \sqrt{\frac{\rho_n \cdot T}{\Delta p \cdot p_2}}$$

under critical

If ΔP is 50-100% of supply pressure, use formula:

$$K_v = \frac{\Phi_{vn}}{257 \cdot p_1} \sqrt{\rho_n \cdot T}$$

overcritical

Units:

Φ_{vn} = flow [m_n^3/h]

p_1 = supply pressure [bara]

p_2 = downstream pressure [bara]

Δp = pressure difference ($p_1 - p_2$) [bard]

T = temperature [K]

ρ_n = density [kg/m_n^3]

The orifice diameter can be determined by:

$$d = 7.6 \sqrt{K_v} \text{ [mm]}$$

4.7.2 For liquids

$$K_v = \Phi_v \sqrt{\frac{\rho}{\Delta p \cdot 1000}}$$

*

Units:

Φ_v = volume flow [m^3/h]

ρ = density at 20°C and 1 atm [kg/m^3]

Δp = delta p [bard]

The orifice bore diameter can be determined by:

$$d = 7.6 \sqrt{K_v} \text{ [mm]}$$

On LFC's only one type of normally closed valve is available. Diameter of orifice can be calculated or looked up in the table.

Diameter [mm]	K _v	Normally closed Δp max. [bard]
0,10	1,73 x 10 ⁻⁴	10
0,14	3,39 x 10 ⁻⁴	10
0,20	6,93 x 10 ⁻⁴	10
0,30	1,56 x 10 ⁻³	10
0,37	2,37 x 10 ⁻³	10
0,50	4,33 x 10 ⁻³	10
0,70	8,48 x 10 ⁻³	10
1,00	1,73 x 10 ⁻²	10

* For liquids having a dynamic viscosity: 15 cP < μ < 100 cP the K_v value should be calculated according to:

$$K_v = \Phi_v \sqrt{\frac{\rho}{\Delta p \cdot 1000}} \cdot \sqrt{\mu}$$

Units:

Φ_v = volume flow [m³/h]

ρ = density at 20°C and 1 atm. [kg/m³]

Δp = delta p [bard]

μ = dynamic viscosity [c_p]

For maximum possible viscosity apply to factory

4.8 Maximum pressure drop

For (pilot) solenoid operated control valves with small orifices the maximum allowable pressure drop for gases is according to the table.

Diameter [mm]	K _v	Normally closed Δp max. [bard]	Normally opened Δp max. [bard]
0,05	4,33 x 10 ⁻⁵	40	30
0,07	8,48 x 10 ⁻⁵	30	20
0,10	1,73 x 10 ⁻⁴	30	20
0,14	3,39 x 10 ⁻⁴	30	20
0,20	6,93 x 10 ⁻⁴	30	20
0,30	1,56 x 10 ⁻³	30	20
0,37	2,37 x 10 ⁻³	30	20
0,50	4,33 x 10 ⁻³	30	20
0,70	8,48 x 10 ⁻³	24	15
1,00	1,73 x 10 ⁻²	12	8
1,30	2,93 x 10 ⁻²	8	5
1,50	3,90 x 10 ⁻²	6	n.a.
1,70	5,00 x 10 ⁻²	5	n.a.
2,00	6,63 x 10 ⁻²	3.6	n.a.

For pilot operated valves the maximum pressure drop is limited to 20 bard. If the pressure drop during start-up is higher, it is preferred to install a bypass valve. During start-up this valve should be opened. Also the minimum pressure drop is limited. For exact figures consult factory or proceed according to the technical data and/or additional instructions given by the sales office or department.

4.9 Calibration procedure

All instruments are factory calibrated. This procedure is for recalibration or range changing only.

Calibration of flow / pressure meters / controllers requires the use of accurate digital volt or current meters, and an accurate calibration device.

General procedure:

- a) Apply power to the system and allow approx. 30 minutes for the instrument to warm up and stabilize.
- b) Check system on operation.
- c) Remove cover during adjustment.
- d) Connect digital meter to the output signal.
- e) Adjust potmeter 'L' till 0% flow/pressure reads 0.010 Vdc output, while disconnecting fluid supply. In case of an absolute pressure sensor, apply vacuum to the system during adjustment.
- f) Adjust potmeter 'H' till 100% flow/pressure reads 5.000 Vdc output.
- g) Adjust potmeter 'M' till 50% flow reads 2.500 Vdc output (not applicable to pressure meters).
- h) Repeat steps 'e' thru 'g' till the deviation between the adjusted and desired values are smaller than the F.S. accuracy needed.

Notes:

- a) In case of other F.S. signal levels, recalculate the 0.010, 2.500 and 5.000 Vdc levels belonging to the 0, 50 and 100% points.
- b) Potmeters 'H' and 'M' can be adjusted without shifting the 'L' adjustment.
- c) Adjusting potmeter 'L' automatically results in a corresponding shift in the positions of potmeters 'H' and 'M'.
- d) Potmeter 'M' can be adjusted without shifting the positions of potmeters 'L' and 'H'.
- e) For the positions of the potmeters consult the instrument specific enclosure.

5 Troubleshooting

5.1 General

For a correct analysis of the proper operation of a flow/pressure meter or controller it is recommended to remove the unit from the process line and check it without applying fluid supply pressure. In case the unit is dirty, this can be ascertained immediately by loosening the compression type couplings and, if applicable the flange on the inlet side.

Furthermore remove the cover and check if all connectors are fixed properly. Energizing or de-energizing of the instrument of the instrument indicates whether there is an electronic failure.

After that, fluid pressure is to be applied in order to check behaviour.

If there should be suspicion of leakage in case of a gas unit, do not check for bubbles with a leak detection liquid under the cover as this may lead to a short-circuit in the sensor or p.c.board.

5.2 Troubleshooting summary

Symptom	Possible cause	Action
No output signal	No power supply	1a) Check power supply
	PCB failure	1b) Check cable
		1c) Return to factory
	Valve blocked	1d) Clean valve (qualified personnel only)
	Filter or screen blocked	1e) Clean filter or screen
	Sensor failure	1f) Return to factory
Maximum output signal	PCB failure	2a) Return to factory
	Sensor failure	2b) Return to factory
High setpoint vs. output offset	PCB failure	3a) Return to factory
	Valve blocked	3b) Clean valve (qualified personnel only)
	Stoppage	3c) Remove cause
	Pressure not correct	3d) Check pressure
Signal lower than expected	System stoppage	4a) Remove cause
Flow is gradually decreasing	(Gas) Condensation	5a) Decrease supply pressure or increase temperature
	Valve adjustment has changed	5b) Check valve adjustment
Oscillation	Controller adjustment wrong	6a) Check controller setting
	Input pressure wrong	6b) Adjust pressure
	Valve damaged	6c) Check valve
	Volume / tubing between controller and pressure controller too small/ short	6d) Improve situation
Small flow occurs when valve is supposed to be closed	Valve is leaking	7a) Check valve

APPENDIX 1

GAS CONVERSION TABLE

Doc. no.: 9.02.071

GAS CONVERSION FACTOR

Nr.:	Name:	Symbol	Density ρ_n [g / l] 0°C, 1 atm.	Heat capacity* c_p – cal [cal / g.K] 20°C, 1 atm.	Conversion factor 20°C, 1 atm.
1	Acetylene (Ethyne)	C ₂ H ₂	1.172	0.438	0.61
2	Air	Air	1.293	0.241	1.00
3	Allene (Propadiene)	C ₃ H ₄	1.832	0.392	0.43
4	Ammonia	NH ₃	0.7693	0.524	0.77
5	Argon	Ar	1.784	0.125	1.40
6	Arsine	AsH ₃	3.524	0.133	0.66
7	Boron trichloride	BCl ₃	5.227	0.136	0.44
8	Boron trifluoride	BF ₃	3.044	0.188	0.54
9	Bromine pentafluoride	BrF ₅	7.803	0.156	0.26
10	Butadiene (1,3-)	C ₄ H ₆	2.504	0.405	0.31
11	Butane	C ₄ H ₁₀	2.705	0.457	0.25
12	Butene (1-)	C ₄ H ₈	2.581	0.415	0.29
13	Butene (2-) (Cis)	C ₄ H ₈	2.503	0.387	0.32
14	Butene (2-) (Trans)	C ₄ H ₈	2.503	0.421	0.30
15	Carbonylfluoride	COF ₂	2.983	0.194	0.54
16	Carbonylsulfide	COS	2.724	0.175	0.65
17	Carbon dioxide	CO ₂	1.977	0.213	0.74
18	Carbon disulfide	CS ₂	3.397	0.152	0.60
19	Carbon monoxide	CO	1.25	0.249	1.00
20	Chlorine	Cl ₂	3.218	0.118	0.82
21	Chlorine trifluoride	ClF ₃	4.125	0.188	0.40
22	Cyanogen	C ₂ N ₂	2.376	0.275	0.48
23	Cyanogen chloride	CICN	2.743	0.185	0.61
24	Cyclopropane	C ₃ H ₆	1.919	0.374	0.43
25	Deuterium	D ₂	0.1798	1.73	1.00
26	Diborane	B ₂ H ₆	1.248	0.577	0.43
27	Dibromo difluoromethane	Br ₂ CF ₂	9.361	0.17	0.20
28	Dichlorosilane	SiH ₂ Cl ₂	4.506	0.17	0.41
29	Dimethylamine	C ₂ H ₆ NH	2.011	0.417	0.37
30	Dimethylpropane (2,2-)	C ₅ H ₁₂	3.219	0.462	0.21
31	Dimethylether	C ₂ H ₆ O	2.105	0.378	0.39
32	Disilane	Si ₂ H ₆	2.857	0.352	0.31
33	Ethane	C ₂ H ₆	1.355	0.468	0.49
34	Ethylene (Ethene)	C ₂ H ₄	1.261	0.414	0.60
35	Ethylene oxide	C ₂ H ₄ O	1.965	0.303	0.52
36	Ethylacetylene (1-Butyne)	C ₄ H ₆	2.413	0.401	0.32
37	Ethylchloride	C ₂ H ₅ Cl	2.878	0.263	0.41
38	Fluorine	F ₂	1.696	0.201	0.91
39	Freon-11	CCl ₃ F	6.129	0.145	0.35
40	Freon-113	C ₂ Cl ₃ F ₃	8.36	0.174	0.21
41	Freon-1132A	C ₂ H ₂ F ₂	2.889	0.244	0.44
42	Freon-114	C ₂ Cl ₂ F ₄	7.626	0.177	0.23
43	Freon-115	C ₂ ClF ₅	7.092	0.182	0.24
44	Freon-116	C ₂ F ₆	6.251	0.2	0.25
45	Freon-12	CCl ₂ F ₂	5.547	0.153	0.37
46	Freon-13	CClF ₃	4.72	0.165	0.40
47	Freon-13B1	CBrF ₃	6.768	0.12	0.38
48	Freon-14	CF ₄	3.946	0.18	0.44
49	Freon-21	CHCl ₂ F	4.592	0.154	0.44
50	Freon-22	CHClF ₂	3.936	0.168	0.47
51	Freon-23	CHF ₃	3.156	0.191	0.52
52	Freon-C318	C ₄ F ₈	9.372	0.222	0.15
53	Germane	GeH ₄	3.45	0.16	0.56

* c_p - cal (T,p) = c_p (T + 50°C, p)

GAS CONVERSION FACTOR

Nr.:	Name:	Symbol	Density ρ_n [g / l] 0°C, 1 atm.	Heat capacity* c_p – cal [cal / g.K] 20°C, 1atm.	Conversion factor 20°C, 1atm.
54	Helium	He	0.1785	1.24	1.41
55	Helium (3-)	3He	0.1346	1.606	1.44
56	Hydrogen	H ₂	0.08991	3.44	1.01
57	Hydrogen bromide	HBr	3.646	0.0869	0.98
58	Hydrogen chloride	HCl	1.639	0.192	0.99
59	Hydrogen cyanide	HCN	1.206	0.345	0.75
60	Hydrogen fluoride	HF	0.8926	0.362	0.96
61	Hydrogen iodide	HI	5.799	0.0553	0.97
62	Hydrogen selenide	H ₂ Se	3.663	0.109	0.78
63	Hydrogen sulfide	H ₂ S	1.536	0.246	0.82
64	Isobutane	C ₄ H ₁₀	2.693	0.457	0.25
65	Isobutylene (Isobutene)	C ₄ H ₈	2.60	0.429	0.28
66	Krypton	Kr	3.749	0.058	1.43
67	Methane	CH ₄	0.7175	0.568	0.76
68	Methylacetylene	C ₃ H ₄	1.83	0.399	0.43
69	Methylbromide	CH ₃ Br	4.35	0.118	0.61
70	Methylchloride	CH ₃ Cl	2.3	0.212	0.64
71	Methylfluoride	CH ₃ F	1.534	0.29	0.70
72	Methylmercaptan	CH ₃ SH	2.146	0.272	0.53
73	Molybdenum hexafluoride	MoF ₆	9.366	0.156	0.21
74	Mono-ethylamine	C ₂ H ₅ NH ₂	2.011	0.436	0.36
75	Monomethylamine	CH ₃ NH ₂	1.419	0.424	0.52
76	Neon	Ne	0.9002	0.246	1.41
77	Nitric oxide	NO	1.34	0.239	0.97
78	Nitrogen	N ₂	1.250	0.249	1.00
79	Nitrogen dioxide	NO ₂	2.053	0.204	0.74
80	Nitrogen trifluoride	NF ₃	3.182	0.194	0.50
81	Nitrosyl chloride	NOCl	2.984	0.17	0.61
82	Nitrous oxide	N ₂ O	1.978	0.221	0.71
83	Oxygen	O ₂	1.429	0.222	0.98
84	Oxygen difluoride	OF ₂	2.417	0.201	0.64
85	Ozone	O ₃	2.154	0.207	0.70
86	Pentane	C ₅ H ₁₂	3.219	0.455	0.21
87	Perchlorylfluoride	ClO ₃ F	4.653	0.165	0.41
88	Perfluoropropane	C ₃ F ₈	8.662	0.22	0.16
89	Performa- ethylene	C ₂ F ₄	4.523	0.206	0.33
90	Phosgene	COCl ₂	4.413	0.149	0.47
91	Phosphine	PH ₃	1.53	0.277	0.73
92	Phosphorous pentafluoride	PF ₅	5.694	0.183	0.30
93	Propane	C ₃ H ₈	2.012	0.456	0.34
94	Propylene (Propene)	C ₃ H ₆	1.915	0.408	0.40
95	Silane	SiH ₄	1.443	0.349	0.62
96	Silicon tetrafluoride	SiF ₄	4.683	0.18	0.37
97	Sulfurylfluoride	SO ₂ F ₂	4.631	0.175	0.38
98	Sulfur dioxide	SO ₂	2.922	0.157	0.68
99	Sulfur hexafluoride	SF ₆	6.626	0.175	0.27
100	Sulfur tetrafluoride	SF ₄	4.821	0.192	0.34
101	Trichlorosilane	SiHCl ₃	6.044	0.157	0.33
102	Trimethylamine	C ₃ H ₉ N	2.637	0.424	0.28
103	Tungsten hexafluoride	WF ₆	13.29	0.092	0.25
104	Vinylbromide	C ₂ H ₃ Br	4.772	0.141	0.46
105	Vinylchloride	C ₂ H ₃ Cl	2.865	0.229	0.47
106	Vinylfluoride	C ₂ H ₃ F	2.08	0.305	0.49
107	Xenon	Xe	5.899	0.0382	1.38

* c_p - cal (T,p) = c_p (T + 50°C, p)

APPENDIX 2

Enclosures (if applicable)

Calibration certificate(s)
Declaration on contamination
Dimensional drawings
Hook-up diagram