



# Instruction manual



## Power supply and readout units E-5700 series

Doc. no.: 9.17.009G Date: 25-07-2011



### ATTENTION

Please read this instruction manual carefully before installing and operating the instrument.  
Not following the guidelines could result in personal injury and/or damage to the equipment.



Even though care has been taken in the preparation and publication of the contents of this manual, we do not assume legal or other liability for any inaccuracy, mistake, misstatement or any other error of whatsoever nature contained herein. The material in this manual is for information purposes only, and is subject to change without notice.

Bronkhorst High-Tech B.V.  
July 2011

## **Warranty**

The products of Bronkhorst High-Tech B.V. are warranted against defects in material and workmanship for a period of three years from the date of shipment, provided they are used in accordance with the ordering specifications and the instructions in this manual and that they are not subjected to abuse, physical damage or contamination. Products that do not operated properly during this period may be repaired or replaced at no charge. Repairs are normally warranted for one year or the balance of the original warranty, whichever is the longer. See also paragraph 9 of the Conditions of Sales.

The warranty includes all initial and latent defects, random failures, and indeterminable internal causes.

It excludes failures and damage caused by the customer, such as contamination, improper electrical hook-up, dropping etc.

Re-conditioning of products primarily returned for warranty service that is partly or wholly judged non-warranty may be charged for.

Bronkhorst High-Tech B.V. prepays outgoing freight charges when any part of the service is performed under warranty, unless otherwise agreed upon beforehand. However, if the product has been returned collect to Bronkhorst High-Tech B.V., these costs are added to the repair invoice. Import and/or export charges, foreign shipping methods/carriers are paid for by the customer.

# TABLE OF CONTENTS

## 1 Introduction

1.1	General description .....	page 5
1.2	Model configuration .....	page 5
1.3	Power supply .....	page 6
1.4	In/output signals .....	page 6
1.4.1	Rearpanel connectors .....	page 6
1.4.2	Connection to measuring and controlling devices .....	page 6
1.4.3	Connection to remote equipment .....	page 6
1.4.3.1	Analog input/output signals .....	page 7
1.4.4	EMC and cables .....	page 7
1.5	Specifications .....	page 8
1.5.1	Housings .....	page 8
1.5.2	Specifications .....	page 9

<b>2</b>	<b>Installation .....</b>	<b>page 10</b>
----------	---------------------------	----------------

<b>3</b>	<b>Recommended spare parts .....</b>	<b>page 11</b>
----------	--------------------------------------	----------------

---

# 1 INTRODUCTION

## 1.1 General description

The Bronkhorst HIGH-TECH B.V. basic module E-5700 has been designed for powering 2 thermal Mass Flow Controllers or Pressure Controllers with 0 - 5 (10 V) output/setpoint.

The output signal is shown on a 3½ -digit voltmeter as 0 ... 100%. Either channel 1 or 2 can be selected by means of a two position switch on the front. The internal/external setpoint switch provides the possibility to either select the required setpoints locally by means of the 10-turn setpoint potentiometers on the front, or use external (computer) signals.

The available modular built systems are described in the model configuration.

## 1.2 Model configuration

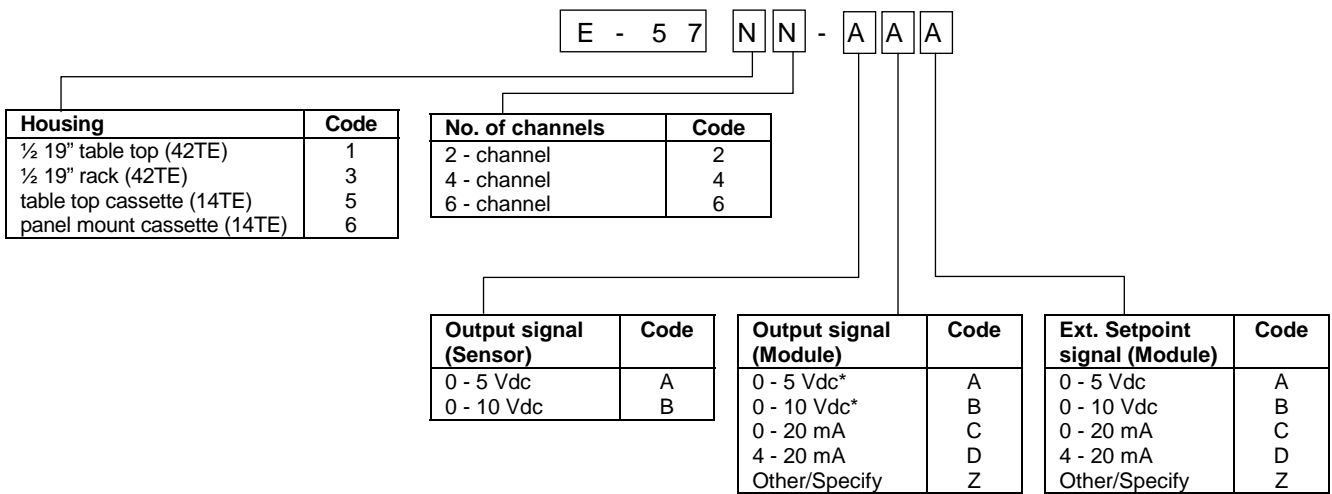

\* Voltage output signal of E-5700 only in combination with identical voltage output signal of sensor.

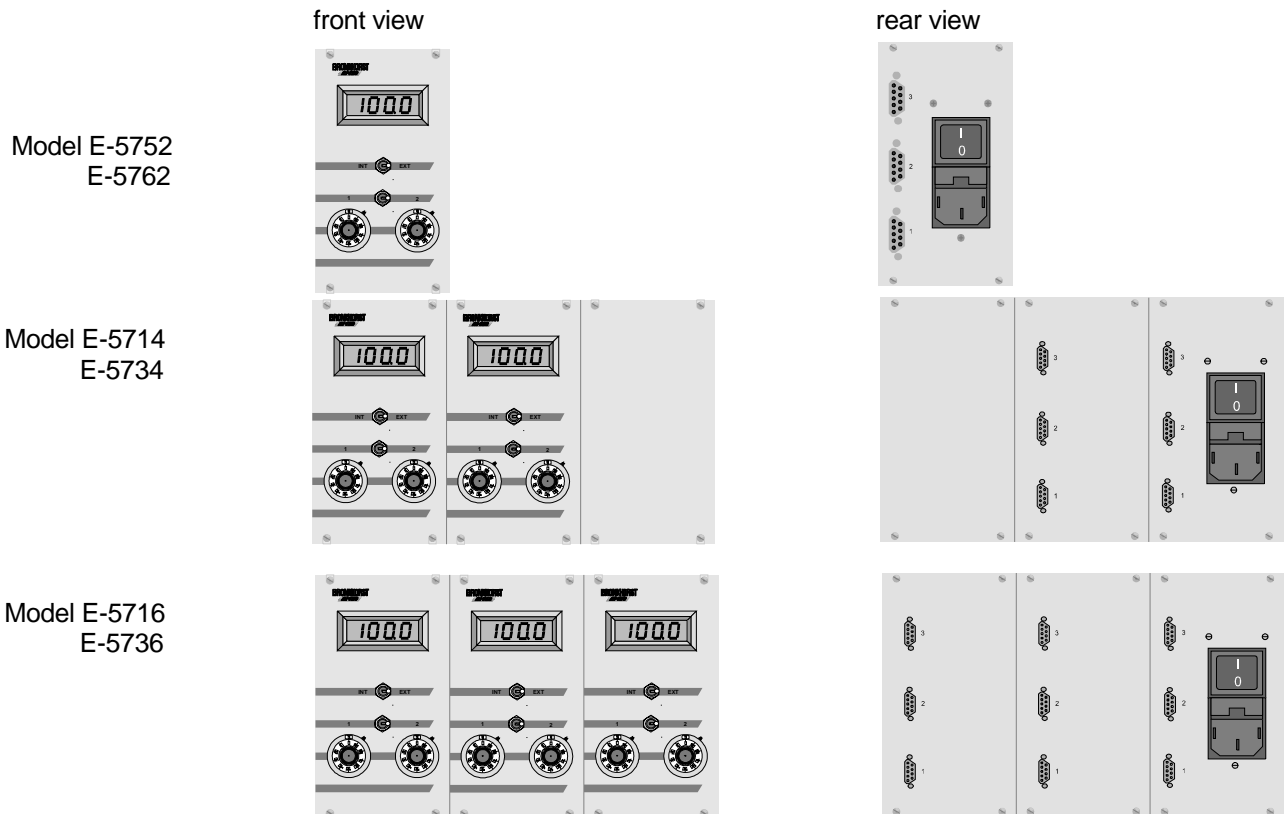

## 1.3 Power supply

Each E-5700 housing incorporates one power supply.

System setup in such that maximal 6 channels are available. The max. number of instruments depends on the individual power requirement of each instrument.

The power input incorporates an on/off switch and a fuse. For extra protection the power supply has a separate internal fuse.

## 1.4 In/output signals

### 1.4.1 Rearpanel connectors

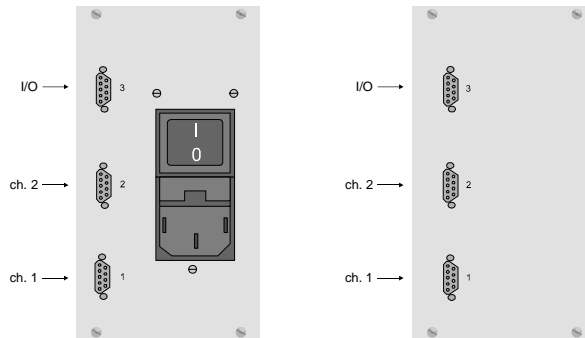

### 1.4.2 Connection to measuring and controlling devices

The instrument connectors 1 and 2 are female sub-miniature 9-pin D-connectors. The pin designation is according to the BRONKHORST HIGH-TECH B.V. standard for analog instruments.

Pin number	description
1	not used
2	0 - 5 (10) Vdc output signal
3	0 - 5 (10) Vdc setpoint signal
4	0 Valve
5	+ Valve
6	- 15 Vdc power supply
7	+ 15 Vdc power supply
8	0 V/common
9	ground/shield

### 1.4.3 Connection to remote equipment

The female in/out (sub-miniature 9-pin) D-connector 3 has the following pin configuration.

Pin number	description
1	Ext. output ch. 1
2	Ext. output ch. 2
3	not used
4	Ext. input ch. 1
5	Ext. input ch. 2
6	not used
7	not used
8	0 V/common
9	ground/shield

### 1.4.3.1 Analog input/output signals

Analog input signals should be connected to pin 4 (+) for channel 1 and/or pin 5 (+) for channel 2 and 0 Vdc/common.

Analog output signals are available at pin 1 (+) for channel 1 and/or pin 2 (+) for channel 2 and 0 Vdc/common. Signals are according to one of the Bronkhorst HIGH-TECH B.V. standards. The model configuration contains a code, describing the input/output signals.

#### Notes:

- Max. load current output : 300 Ohm (sourcing output)
- Min. load voltage output: 10 kOhm
- Input load resistance (voltage) 1 MOhm
- Input load resistance (current) 61,4 Ohm (sinking input)

### 1.4.4 EMC and cables

The system setup described in this manual carries the CE-mark. Therefore it has to comply with the EMC requirements as are valid for this kind of equipment.

**However compliance with the EMC requirements is not possible without the use of proper cables and connector assemblies.**

For good results Bronkhorst HIGH-TECH B.V. can provide standard cables. Otherwise follow the guidelines as stated below.

Fold the shield of the cable back over the cable (the shield must be around the cable).

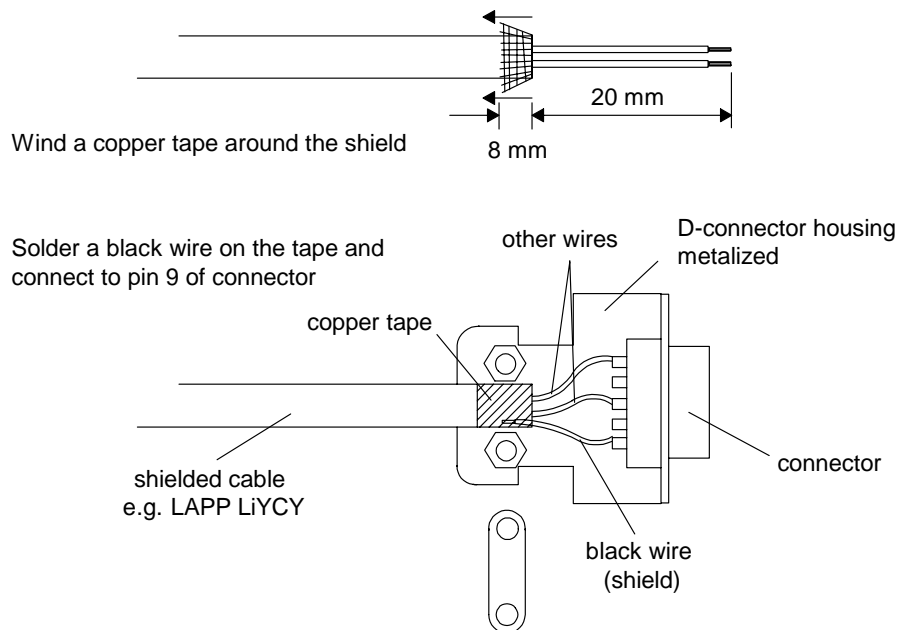

#### Note:

When connecting the system to other devices (e.g. I/O to PLC), be sure that the integrity of the shielding is not affected. Do not use unshielded wire terminals.

## 1.5 Specifications

### 1.5.1 Housings

#### 14 TE table top cassette

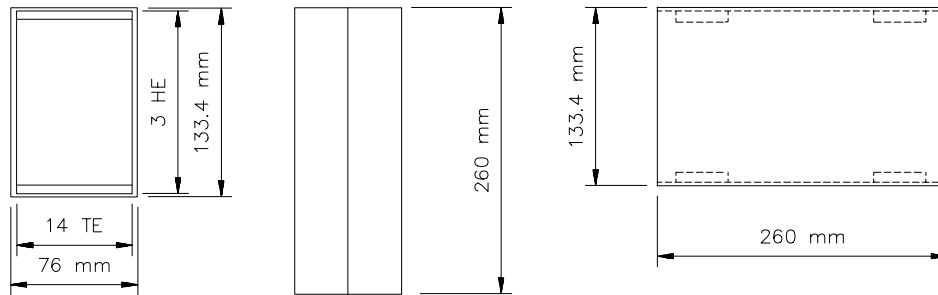

#### 14 TE panel mount

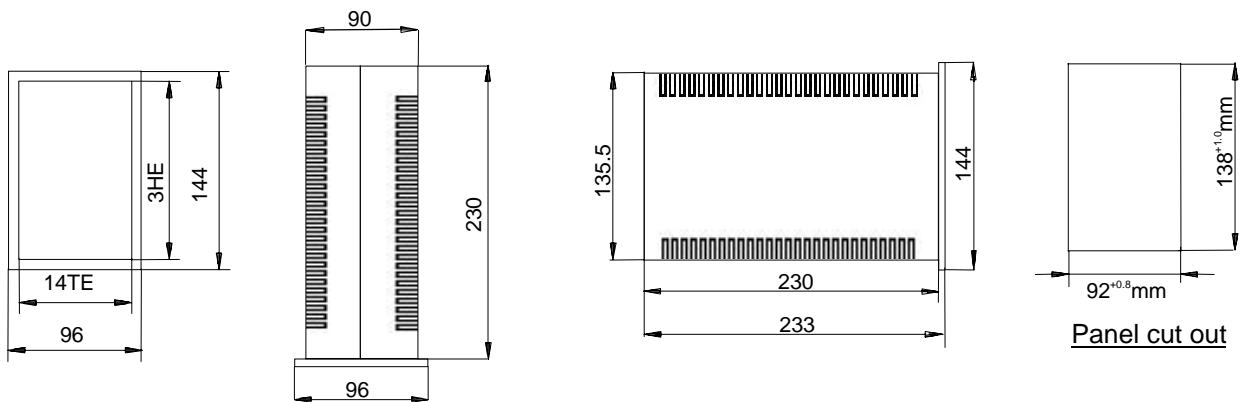

#### 42 TE ½ 19" table top

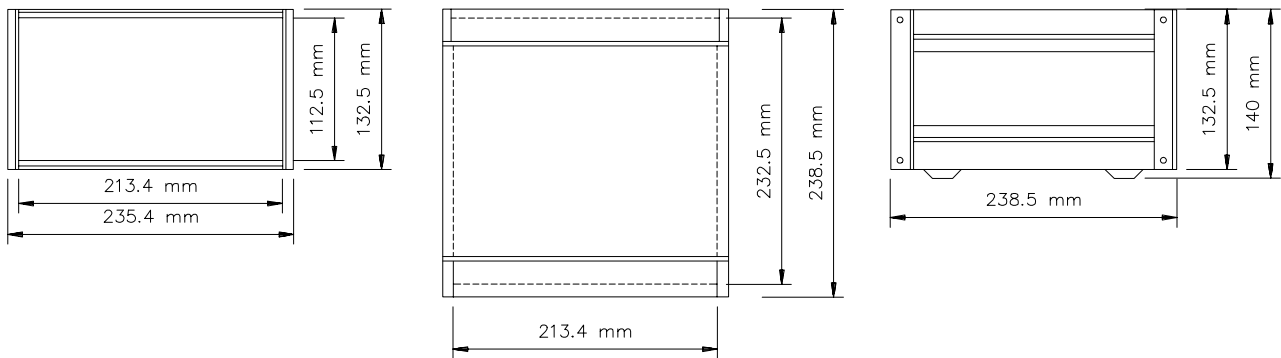

#### 42 TE ½ 19" rack mount

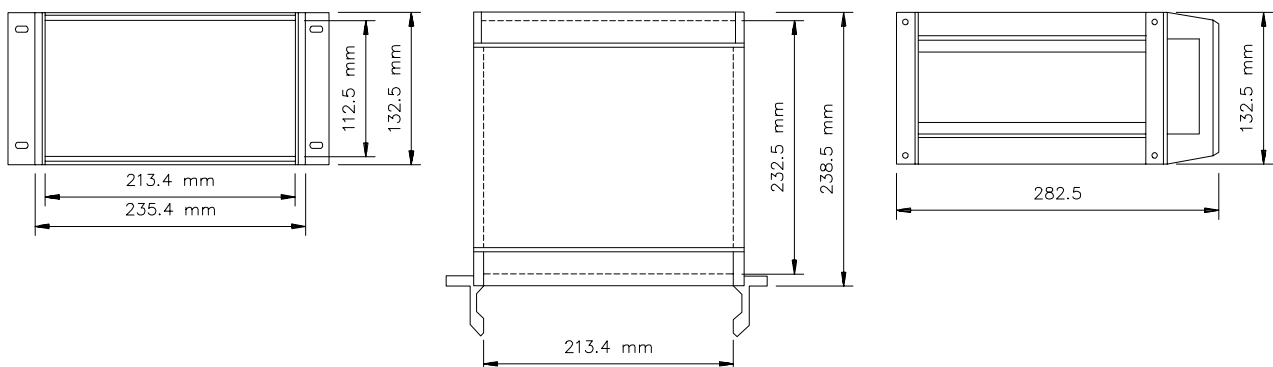

### 1.5.2 Specifications

Power supply	:	100 ... 240 Vac, 50 ... 60 Hz, 40 VA
Signal input	:	consult model configuration
Signal output	:	consult model configuration
Connectors	:	two 9-pin subminiature D-connectors (female) for instrument connection one 9-pin subminiature D-connector (female) for external output signal and external setpoint signal including mating connector
Fuse	:	consult system label
Front	:	- one 3½ -digit LED indicator for indication 0 ... 100,0 % - two setpoint potentiometers with micrometer knob setting - one 2-position switch for DVM channel selection - one 2-position switch for internal/external setpoint mode
Setpoint potmeter	:	two 10-turn dial with 5 kOhm potentiometers
Operating temp.	:	0 - 50 °C ambient
Housing	:	IP - 20

Note :

Never block ventilation holes.

Operation at high ambient temperatures over extended periods may lead to reduction of the operating lifetime of your power supply / readout system.

## 2 INSTALLATION

### **Receipt of equipment:**

Check the outside packing for damage incurred during shipment.

Should the packing box be damaged, then the local carrier must be notified at once regarding his liability, if so required.

At the same time a report should be submitted to Bronkhorst HIGH-TECH B.V. Ruurlo Holland

Remove the envelope containing the packing list; carefully remove the equipment from the packing box. do not discard spare or replacement parts with the packing material and inspect the contents for damaged or missing parts.

### **Return shipment:**

When returning material: always describe the problem and if possible the work to be done, in a covering letter.

### **Important:**

Clearly note, on top of package the custom clearance number of Bronkhorst High-Tech B.V. namely:

NL801989978B01

### **Service:**

If this equipment is not properly serviced, serious personal injury and/or damage to the equipment could result. It is therefore important that servicing is performed by trained and qualified service personnel. Bronkhorst HIGH-TECH B.V. have a trained staff of servicemen available.

### **Installation:**

By connecting the cable to the 100 ... 240 Vac source, the readout/control unit can operate. The DVM shows 000.0 (only if no external meter or controller has been connected to the housing).

If the LED's of display do not light on, please check fuse in 100 ... 240 Vac connection plug.

Depending on the execution the units can:

- 1) power external sensors Eurostyle:
  - +15 Vdc/350 mA
  - 15 Vdc/50 mA
- 2) display signals 0 - 5(10) Vdc = 0 - 100.0 % reading
- 3) power command setpoint signals 0 - 5(10) Vdc to external controller.

### 3 RECOMMENDED SPARE PARTS

	Partnumber:
Power supply 100 .. 240 Vac	1.16.027
Display 3½ -digit	1.08.014
2-position switch	1.14.002
Potmeter 5 kOhm	1.12.001
10-turn dial	1.13.003