

◆ ◆ ◆ ◆ ◆  
◆ ◆ ◆ ◆ ◆  
Instruction manual

◆ ◆ ◆ ◆ ◆  
◆ ◆ ◆ ◆ ◆  
**FLOW-SMS series**  
**Surface Mount System for Digital**  
**Mass Flow / Pressure**  
**Meters and Controllers**

Doc. no.: 9.17.057E Date: 26-07-2011

◆ ◆ ◆ ◆ ◆  
◆ ◆ ◆ ◆ ◆  
◆ ◆ ◆ ◆ ◆  
◆ ◆ ◆ ◆ ◆  
**ATTENTION:**  
Please read this instruction manual carefully before installing and operating the instrument.  
Not following the guidelines could result in personal injury and/or damage to the equipment.

## Disclaimer

Even though care has been taken in the preparation and publication of the contents of this manual, we do not assume legal or other liability for any inaccuracy, mistake, mis-statement or any other error of whatsoever nature contained herein. The material in this manual is for information purposes only, and is subject to change without notice.

Bronkhorst High-Tech B.V.  
July 2011

## Symbols



*Important information. Discarding this information could cause injuries to people or damage to the Instrument or installation.*



*Helpful information. This information will facilitate the use of this instrument.*



*Additional info available on the internet or from your local sales representative.*

## Receipt of equipment

Check the outside packing box for damage incurred during shipment. Should the packing box be damaged, then the local carrier must be notified at once regarding his liability, if so required. At the same time a report should be submitted to your distributor.

Carefully remove the equipment from the packing box. Verify that the equipment was not damaged during shipment. Should the equipment be damaged, then the local carrier must be notified at once regarding his liability, if so required. At the same time a report should be submitted to your distributor.



*Before installing an FLOW-SMS System it is important to read the attached labels and check:*

- Flow rate(s) / Pressure rate(s)
- Fluid(s) to be measured
- Up- and downstream pressures
- Input/output signals
- Temperature



*Do not discard spare or replacement parts with the packing material and inspect the contents for damaged or missing parts.*

Refer to chapter 6 about return shipment procedures.

## Equipment storage

The equipment should be stored in its original packing in a cupboard warehouse or similar. Care should be taken not to subject the equipment to excessive temperatures or humidity.

## **Warranty**

The products of Bronkhorst High-Tech B.V. are warranted against defects in material and workmanship for a period of three years from the date of shipment, provided they are used in accordance with the ordering specifications and the instructions in this manual and that they are not subjected to abuse, physical damage or contamination. Products that do not operate properly during this period may be repaired or replaced at no charge. Repairs are normally warranted for one year or the balance of the original warranty, whichever is the longer.



*See also paragraph 9 of the Conditions of sales:*

*[http://www.bronkhorst.com/files/corporate\\_headquarters/sales\\_conditions/en\\_general\\_terms\\_of\\_sales.pdf](http://www.bronkhorst.com/files/corporate_headquarters/sales_conditions/en_general_terms_of_sales.pdf)*

The warranty includes all initial and latent defects, random failures, and undeterminable internal causes.

It excludes failures and damage caused by the customer, such as contamination, improper electrical hook-up, physical shock etc.

Re-conditioning of products primarily returned for warranty service that is partly or wholly judged non-warranty may be charged for.

Bronkhorst High-Tech B.V. prepays outgoing freight charges when any part of the service is performed under warranty, unless otherwise agreed upon beforehand. However, if the product has been returned collect to Bronkhorst High-Tech B.V., these costs are added to the repair invoice. Import and/or export charges, foreign shipping methods/carriers are paid for by the customer.

**Table of contents**

<b>1</b>	<b>SCOPE OF THIS MANUAL.....</b>	<b>5</b>
1.1	Introduction.....	5
1.2	References to other applicable documents .....	5
<b>2</b>	<b>STARTING UP.....</b>	<b>6</b>
2.1	Check properties.....	6
2.2	Rated pressure test inspection .....	6
2.3	Check piping .....	6
2.4	Install system .....	7
2.5	Leak check .....	7
2.6	Electrical connection .....	7
2.7	Analog / Digital operation .....	8
2.8	Multi-functional switch operation.....	8
2.9	Purging.....	8
2.10	Zeroing.....	9
2.11	Calibration .....	9
2.12	Supply pressure .....	9
2.13	Description .....	10
2.13.1	Introduction.....	10
2.13.2	Functional modules .....	10
2.13.3	Flow modules .....	10
2.13.4	Pressure modules .....	11
2.13.5	Solenoid Operated shut off valves .....	13
2.13.6	Toggle valves .....	13
2.13.7	Needle valves.....	14
2.13.8	Pneumatic operated shut off valves.....	14
2.13.9	Pneumatic operated shut off 3/2 valves .....	15
2.13.10	Filter modules.....	15
2.13.11	Blind/Flow plates.....	16
2.14	Model key.....	17
<b>3</b>	<b>BASIC OPERATION .....</b>	<b>18</b>
3.1	General .....	18
3.2	Analog operation .....	18
3.3	Manual interface: micro-switch and LED's.....	18
3.4	RS232 FLOW-BUS operation.....	18
3.5	Fieldbus operation.....	20
<b>4</b>	<b>ADVANCED OPERATION.....</b>	<b>21</b>
4.1	Using mass flow meters/controllers on different gases or under different conditions .....	21
4.1.1	Stored calibration curves.....	21
4.1.2	Multi Fluid / Multi Range instruments .....	21
4.1.3	Conversion factor calculation using Fluidat software .....	21
4.1.4	Sealing material .....	21
4.1.5	Maximum pressure drop .....	22
<b>5</b>	<b>TROUBLESHOOTING AND SERVICE .....</b>	<b>23</b>
5.1	General .....	23
5.2	LED indication .....	23
5.3	Troubleshooting summary general .....	24
5.4	Service .....	25
<b>6</b>	<b>REMOVAL AND RETURN INSTRUCTIONS .....</b>	<b>26</b>

# 1 Scope of this manual

## 1.1 Introduction

This manual covers the FLOW-SMS series, Bronkhorst High-Tech's light weight, modular gas delivery system. It handles the general instructions needed for the surface mount components, i.e. digital mass flow / pressure meters and controllers, control valves, shut-off valves and filters, as well as the manifold components such as mixing and distribution chambers, support rails and adapter plates.

FLOW-SMS systems are assembled according to customer's specifications. The ranges for the flow sensor can be selected between approx. 5 ml<sub>n</sub>/min up to 50 l<sub>n</sub>/min or even higher. In case a pressure sensor is included, the pressure range can be chosen between 0-100 mbar and 0-10 bar absolute or gauge. Depending on the application the customer may prefer a system with face seal fittings, compression type couplings, or flanges according to customers' specification. On request, the system will be assembled, tested, and packaged in a cleanroom.

**Example:**



## 1.2 References to other applicable documents

FLOW-SMS instruments have modular instruction manuals consisting of:

- **FLOW-SMS series (document nr. 9.17.057)**
- Operation instructions digital instruments (document nr. 9.17.023)
- Optional fieldbus/interface descriptions:
  - FLOW-BUS interface (document nr. 9.17.024)
  - PROFIBUS<sup>®</sup>-DP interface (document nr. 9.17.025)
  - DeviceNet<sup>™</sup> interface (document nr. 9.17.026)
  - RS232 interface with FLOW-BUS protocol (document nr. 9.17.027)
  - Modbus interface (document nr. 9.17.035)
- Hook-up diagrams for analog, RS232 and fieldbus operation
- Dimensional drawing (document nr. 7.05.813)



These documents, except for the dimensional drawing, can be found in PDF format on the CD "Documentation and software tools", furnished with the delivered instruments. The documents are also available on: <http://www.bronkhorst.com/en/downloads> or can be applied for at our local sales & service representatives

## 2 Starting up

### 2.1 Check properties



Before installing a FLOW-SMS system it is important to **read the attached labels and check:**

- Flow rates / Pressure rate(s)
- Fluids to be measured
- Up- and downstream pressures
- Input/output signal
- Temperature

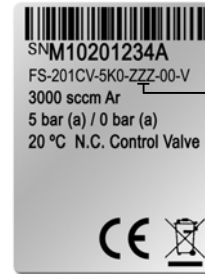

input/output  
 A – 0...5 Vdc  
 B – 0...10 Vdc  
 F – 0...20 mA  
 G – 4...20 mA



Check if the **sealing material** like O-rings, plunger and packing gland of capillary are suitable for the used gas and process. The Flow module is fitted with Viton, EPDM or Kalrez seals. Which sealing material is used is shown in the last character of the model key. The rest of FLOW-SMS system also contains sealings, which are selected based on the fluid flow schematic diagram.

### 2.2 Rated pressure test inspection



Each FLOW-SMS system is **pressure tested** to at least 1.5 times the working pressure of the process conditions stipulated by the customer, with a minimum of 8 bar.

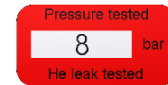

Pressure Testing Sticker

Each instrument is **helium leak tested** to at least  $2 \cdot 10^{-9}$  mbar l/s Helium outboard.



The tested pressure is stated on the instrument with a **RED COLOURED** sticker. Before installation, make sure that the test pressure is in accordance with normal safety factors for your application. If there is no Pressure Testing Sticker on the device or if the test pressure is incorrect, the instrument should **not** be mounted in the process line and be returned to the factory.

### 2.3 Check piping



For reliable measurement always make sure the fluid stream is clean.

Use filters to assure a moisture-, oil- and particle-free gas stream.

Recommended pore-size: 7  $\mu\text{m}$ .

If back flow can occur, a downstream filter and a check valve are recommended too.

For particle filtering the FLOW-SMS program offers sintered filter modules with porosities 0.5, 2, 7, and 15 micron



## 2.4 Install system



Install the FLOW-SMS assembly in accordance with the directions following the **schematic diagram**.

Tighten the fittings according to the instructions.

**For compression type adapters**, slide the nut and the ferrule set in the right order at the tube. Insert the tubing fully into the Adapter plate against the shoulder. Rotate the nut finger-tight, while holding the fitting body steady. Tighten the nut three quarters clockwise for the fittings up to 4 mm and 3/16" tube OD. For larger fittings, tighten the nut one and one-quarter.

**For metal and o-ring face seal type**, rotate the nut finger-tight, then turn the nut one-quarter clockwise, which is sufficient for the sealing. When the Adapter Plate is replaced the complete module has to be tested for leakage and function.

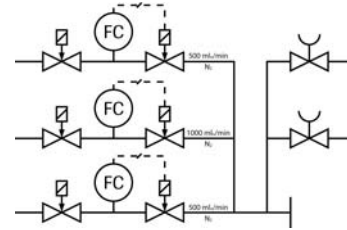

The preferred mounting position of mass flow or pressure meters/controllers is horizontal. Other mounting positions may introduce a zero shift and/or little gas and pressure dependency of the zero signal. When mounting the assembly other than horizontal, zeroing of the instruments is advised. The zeroing procedure is described in paragraph 2.10.



Avoid installation in close proximity of mechanic vibration and/or heat sources.

## 2.5 Leak check



Check the system for leaks before applying (fluid) pressure. Especially if toxic, explosive or other dangerous fluids are used!

## 2.6 Electrical connection



Electrical connections must be made with standard cables or according to the applicable **hook-up diagrams**. These documents can be found at:

<http://www.bronkhorst.com/en/downloads>



Please note that FLOW-SMS instruments are rated **IP40**, implying that the electronics housings and electrical connections do not offer any protection against moist environments.



The instruments contain electronic components that are susceptible to damage by **electro static discharge**. Proper handling procedures must be taken during installation, removing and connecting the electronics.



All instruments described in this manual carry the CE-mark and are **compliant with the EMC requirements**. However compliance with the EMC requirements is not possible without the use of proper cables and connector/gland assemblies. For good results Bronkhorst High-Tech B.V. can provide standard cables. Otherwise follow the guidelines as stated hereby.

Fold the shield of the cable back over the cable (the shield must be around the cable).

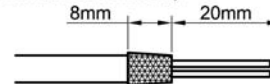

Wind a copper tape around the shield

Solder a black wire on the tape and connect to pin 9 of the connector.

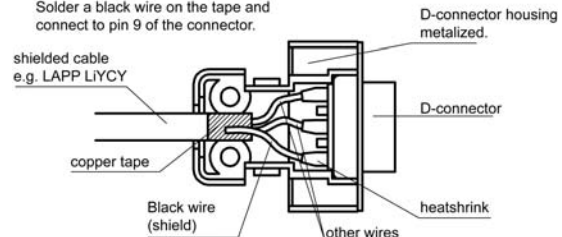



When connecting the system to other devices (e.g. to PLC), be sure that the integrity of the **shielding** is not affected. Do not use unshielded wire terminals.



Operation via fieldbus is done by means of a **flatconductor cable** connected with the main PC board.

Although all functionality is possible by means of RS232 and the switch on top of the instrument, it is important that care should be taken when removing the upper part of the housing.



In case that a shut-off valve is mounted directly behind a control module, please apply a **right angled connector** for Analog/RS232 communication.



## 2.7 Analog / Digital operation



### 2.7a Analog/Local operation

Connect the Mass Flow or Pressure Meter/Controller to the power supply/readout unit using a cable with 9-pin sub-D connector.



### 2.7b Digital/Fieldbus operation

For this procedure see description for RS232 or the applicable fieldbus operation.

RS232 connection cable 7.03.366 enables to use (free) Bronkhorst tooling programs for Windows.

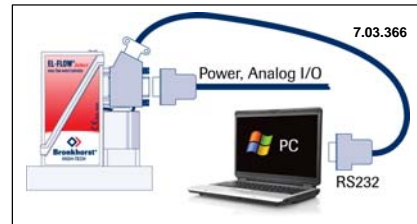

## 2.8 Multi-functional switch operation



Using the 2 colored LEDs and the switch on the instruments, several actions can be monitored and started. The green LED is used for status indication. The red LED is used for errors/warnings/messages. The switch can be used to start several actions, such as auto-zero, restore factory settings and bus-initialization actions, if applicable.

See specific zero-procedure below (10) for more details.

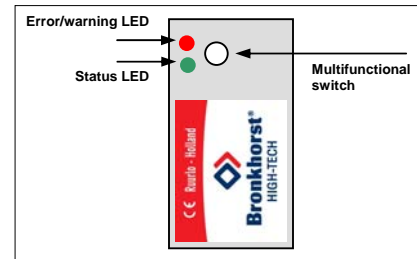

## 2.9 Purging



*In systems for use with corrosive or reactive fluids, purging for at least 30 minutes with a dry, inert gas (like Nitrogen or Argon) is absolutely necessary before use. After use with corrosive or reactive fluids, complete purging is also required before exposing the system to air.*



### **Warm-up time:**

*Let the instruments warm-up for at least 30 minutes for best accuracy.*

*During warm-up period, fluid pressure may either be on or off.*

## 2.10 Zeroing



*The zero-point of each instrument is factory adjusted. If so required the zero point may be re-adjusted over RS232 or fieldbus or by means of using the micro switch. Procedure for zeroing by micro switch:*

- ◆ *Warm-up, pressure up the system and fill the instrument according to the process conditions.*
- ◆ *Make sure no flow is going through the instrument by closing valves near the instrument.*
- ◆ *The setpoint must be zero.*
- ◆ *Press micro switch and hold it. After a short time the red LED will go ON and OFF, then the green LED will go ON. At that moment release the micro switch.*
- ◆ *The zeroing procedure will start at that moment and the green LED will blink fast. The zeroing procedure waits for a stable signal and saves the zero. If the signal is not stable, zeroing will take long and the nearest point to zero is accepted. The procedure will take approx. 10 seconds.*

*When the indication is showing 0% signal and the green indication LED is burning continuously again, then the zeroing action was successful.*

## 2.11 Calibration

Each FLOW-SMS instrument is factory calibrated. Calibration certificates are included in the shipment. When operated properly (clean gases, no pressure shocks, no vibrations, no thermal shocks, etc), regular maintenance is not required. However, periodical inspection, recalibration or verification of the accuracy may be subject to individual requirements of the end-user. Please refer to the internal operational requirements of your company.

## 2.12 Supply pressure



*It is recommended to turn on power before applying pressure on the instrument and to switch off power after removing pressure.*



*Turn on fluid supply gently. Avoid pressure shocks and bring the instrument gradually up to the level of the actual operating conditions. Also switch off fluid supply gently.*

## 2.13 Description

### 2.13.1 Introduction

FLOW-SMS systems are compact mounting rail assemblies, containing one or more mass flow or pressure sensor modules, that can be combined with control valves, shut-off valves, mixing chambers, filters or any other functional module as per customer's request.

Also the manifold on which the functional modules are mounted consists of a modular assembly of support rails, base bodies and adapter or blind plates.



### 2.13.2 Functional modules

The pictures on the right side illustrate the modular concept of the FLOW-SMS system. It offers great flexibility for the end-user with respect to modifications and serviceability. The functional modules are 'top-mount', so they can easily be exchanged without removing the total assembly.

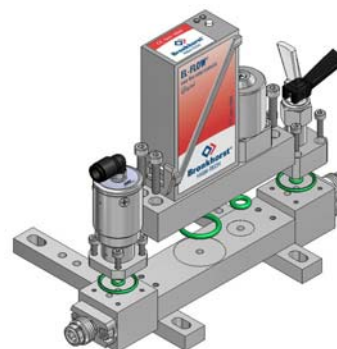

In the following paragraphs we have laid down the instructions for removal and replacement of functional modules.



*Bronkhorst High-Tech recommends to clean or to replace gaskets and hexagon bolts before reassembling functional modules.*



*FLOW-SMS manifold components (base bodies, distribution and mixing chamber, etc.) should only be removed or replaced by qualified personnel.*

### 2.13.3 Flow modules

#### - General information

The **gas flow sensor** operates on a principle of heat transfer by sensing the temperature difference along a heated section of a capillary tube. Part of the total flow is forced through the capillary by means of a laminar flow element in the main stream generating a pressure difference. The design of the laminar flow device is such that flow conditions in both the capillary and laminar flow device are comparable, thereby resulting in proportional flow rates through the meter. The  $\Delta T$  sensed by the upstream and downstream temperature sensors on the capillary depends on the amount of heat absorbed by the gas flow.

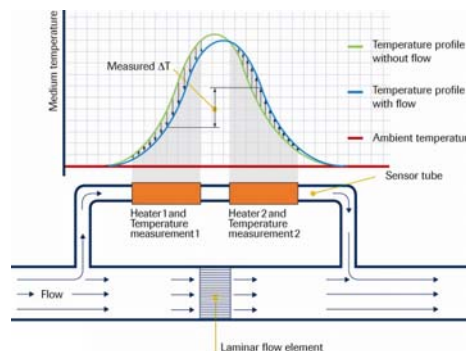

*Each instrument has been calibrated and adjusted for customer process conditions. The performance and accuracy may be affected tremendously if physical fluid properties such as heat capacity and viscosity change due to changing process conditions. For operation on other gases see paragraph 4.1.*

The **control valve** used in the FLOW-SMS series is a standard, direct operated solenoid valve (normally opened or normally closed), operated through the PID-control function on the pc-board of the flow or pressure meter. The diameter of the orifice under the plunger is optimised for the customer's specification.



*Controllers or valves may not operate correctly, if process conditions vary too much, because of the restriction of the orifice in the valve.*

Instructions for replacing a Mass Flow Meter (MFM) or Mass Flow Controller (MFC) module:

**Removal**

Ensure that the system is depressurised before taking Flow module apart.  
The power must be off when removing the electrical connectors.  
Loosen the 4 bolts (M4) with hexagon head counter clockwise to release the Flow module.

**Replacement**

Replace the gaskets depending on the type: FS-200CV 2xAS-108, FS-201CV 1xAS-115 and 1xAS-108, FS-202CV 1xAS-118 and 1xAS-108. Viton (green), EPDM (purple) or Kalrez (black).  
All wetted parts have to be absolutely clean, don't use oil or grease and avoid dust!  
Replace the Flow module and tighten the M4 bolts with hexagon head by turning clockwise, tighten crosswise with 2.6 Nm.  
Reattach the electrical connector.  
Now the Flow module has to be tested for leakage and function.

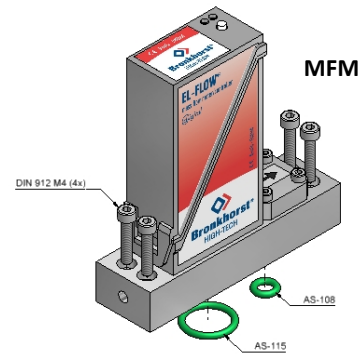
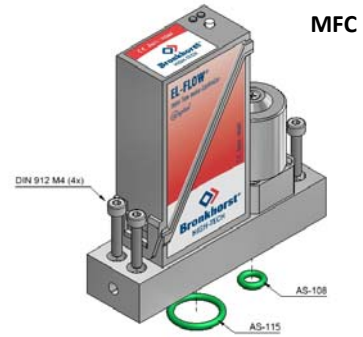

**Available Mass Flow Controller / Mass Flow Meter modules**

Type	Type	Nominal Range	Description
<b>Controller (MFC)</b>	<b>Meter (MFM)</b>		Range (based on N2@ 1 bara
FS-200CV	FS-100C	5	0.06...3 up to 0,18...9 mln/min
FS-201CV	FS-101C	20	0.16...8 up to 0,6...30 mln/min
FS-201CV	FS-101C	50	0,4...20 up to 1,5...75 mln/min
FS-201CV	FS-101C	100	0,8...40 up to 3...150 mln/min
FS-201CV	FS-101C	200	1,6...80 up to 6...300 mln/min
FS-201CV	FS-101C	500	4...200 up to 15...750 mln/min
FS-201CV	FS-101C	1k0	8...400 up to 30...1500 mln/min
FS-201CV	FS-101C	2k0	16...800 up to 60...3000 mln/min
FS-201CV	FS-101C	5k0	0,04...2 up to 0,15...7,5 ln/min
FS-201CV	FS-101C	7k0	0,05...2.6 up to 0,2...10 ln/min
FS-202CV	FS-102C	10k	0.08...4 up to 0.3...15 ln/min
FS-202CV	FS-102C	20k	0,16...8 up to 0.6...30 ln/min
FS-202CV	FS-102C	35k	0,25...12.5 up to 1...50 ln/min

**2.13.4 Pressure modules**

FLOW-SMS pressure meters/controllers range from 100 mbar up to 10 bar, measuring either absolute pressure or gauge pressure, with a very high accuracy and repeatability. The instruments are equipped with a diaphragm based **piezo-resistive sensor**. Pressure controllers are available as forward controller (P-600 series) and backward controller (P-700 series).  
The flow going through the pressure controller depends on up and downstream pressures, orifice diameter of the valve and the density of the fluid.

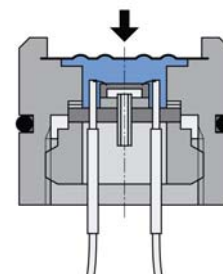

The **control valve** used in the FLOW-SMS series is a standard, direct operated solenoid valve (normally opened or normally closed), operated through the PID-control function on the pc-board of the flow or pressure meter. The diameter of the orifice under the plunger is optimised for the customer's specification.



*In pressure control systems the system widely determines the response behaviour of the control loop. During testing the customer system is simulated as closely as possible. In some cases however readjustment is needed for optimum performance under actual conditions.*

Instructions for replacing a Pressure Meter (PM) or Pressure Controller (PC) module:

**Removal**

Ensure that the system is depressurised before taking Pressure module apart.  
The power must be off when removing the electrical connectors.  
Loosen the 4 bolts with hexagon head counter clockwise to release the Pressure module.

**Replacement**

Replace the gaskets 2xAS-108, Viton (green), EPDM (purple) or Kalrez (black).  
All wetted parts have to be absolutely clean, don't use oil or grease and avoid dust!  
Replace the Pressure module and tighten the M4 bolts with hexagon head by turning clockwise, tighten crosswise with 2.6 Nm.  
Replace the electrical connector.  
Now the Pressure module has to be tested for leakage and function.

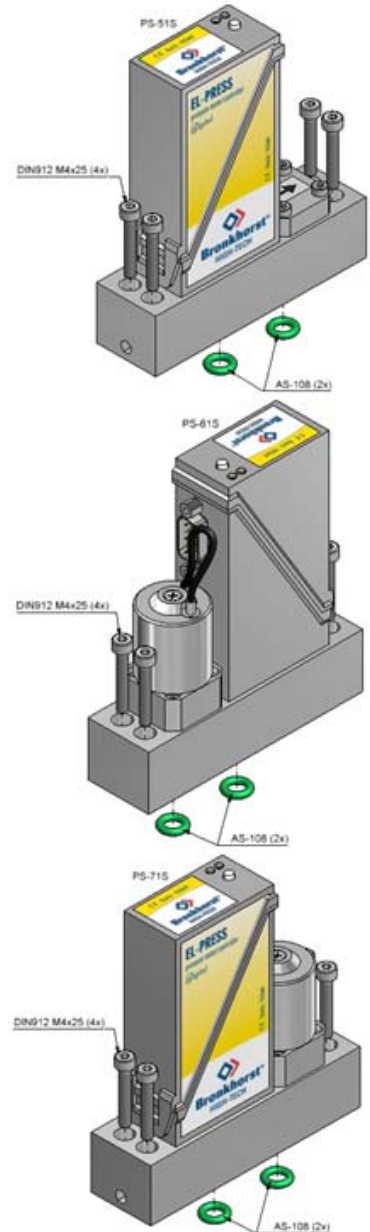

**Available Pressure Controller / Pressure Meter modules**

Pressure Module		Description	
Model number	Function	Smallest range	Highest range
PS-502C	Meter	2...100 mbar	0,2...10 bar
PS-602CV-NC	Controller forward (NC)	5...100 mbar	0,5...10 bar
PS-702CV-NC	Controller back (NC)	20...100 mbar	2...10 bar

Pressure range (FS) (bar)	Identification in model key	
	Absolute	Relative
0,1 - 0,35	350A	350R
0,35 - 1,1	1k1A	1k1R
1,1 - 6,0	6k0A	6k1R
6,0 - 21	21kA	21kR

Please keep in mind that the pressure rating for FLOW-SMS is 10 bar only.

### 2.13.5 Solenoid Operated shut off valves NC and NO

**Removal**

Ensure that the system is depressurised before taking shut off valve apart.  
 The power must be off when removing the electrical connectors.  
 Remove the coil by releasing the clip on top of the coil for the normally closed, and the nut for the normally opened.  
 Loosen the 2 bolts with hexagon head counter clockwise to release the valve.

**Replacement**

Replace the gaskets AS-007 and AS-017, Viton (green), EPDM (purple) or Kalrez (black).  
 All wetted parts have to be absolutely clean, don't use oil or grease and avoid dust!  
 Replace the shut off valve and tighten the bolt with hexagon head by turning clockwise, tighten crosswise with M3 1.1 Nm.  
 Replace the coil and replace the clip on top of the coil normally closed, and the nut for the normally opened.  
 Replace the electrical connector.  
 Now the shut off valve has to be tested for leakage and function.

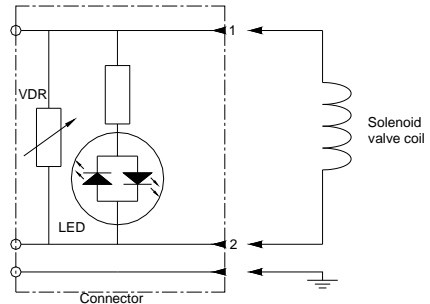
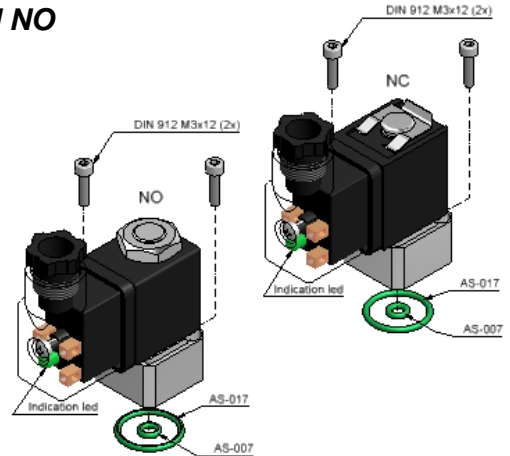

Hook- up solenoid operated valve.  
 Supply voltage + 24Vdc  
 Power consumption 3 Watt.

**Available electric shut off valves**

Model number	Description	
EV-02-NC-V(iton)	Kv=0,065	Max deltaP 3 bar
EV-02-NC-E(PDM)	Kv=0,065	Max deltaP 3 bar
EV-02-NC-K(kalrez)	Kv=0,065	Max deltaP 3 bar
EV-02-NO-V(iton)	Kv=0,065	Max deltaP 3 bar

### 2.13.6 Toggle valves

**Removal**

Ensure that the system is pressure less before taking the toggle valve apart.  
 Loosen the 4 bolts with hexagon head counter clockwise to release the toggle valve.

**Replacement**

Replace the gaskets AS-007 and AS-017, Viton (green), EPDM (purple) or Kalrez (black).  
 All wetted parts have to be absolutely clean, don't use oil or grease and avoid dust!  
 Replace the toggle valve centre before tighten the bolt with hexagon head by turning clockwise, tighten crosswise with M3 1.1 Nm.  
 Now the toggle valve has to be tested for leakage and function.

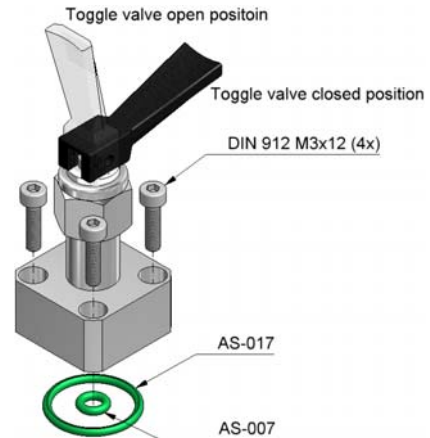

**Available Toggle valves**

Model number	Description	
TV-01-V	Kv=0,09	Toggle Valve with Viton seals
TV-01-E	Kv=0,09	Toggle Valve with EPDM seals
TV-01-K	Kv=0,09	Toggle Valve with Kalrez seals

### 2.13.7 Needle Valves

#### Removal

Ensure that the system is depressurised before taking the needle valve apart.

Loosen the 4 bolts with hexagon head counter clockwise to release the needle valve.

#### Replacement

Replace the gaskets AS-007 and AS-017, Viton (green), EPDM (purple) or Kalrez (black).

All wetted parts have to be absolutely clean, don't use oil or grease and avoid dust!

Replace the needle valve centre before tighten the bolt with hexagon head by turning clockwise, tighten crosswise with M3 1.1 Nm.

Now the needle valve has to be tested for leakage and function.

#### Adjustment

The needle valves are adjustable with a slotted head screwdriver to adjust the flow. The NV-01 is also lockable with a nut because the fine adjustability.

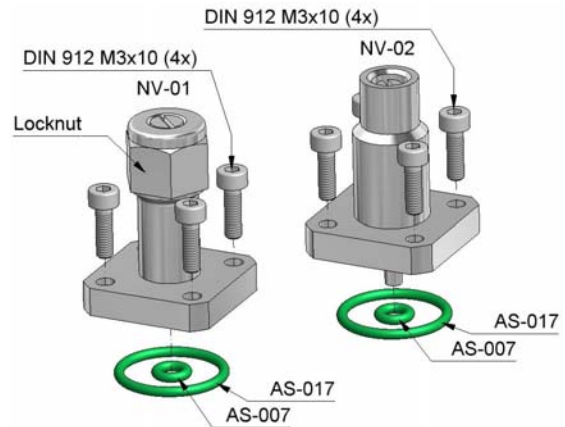

#### Available Needle valves

Model number	Description	
NV-01	Kvmin $1.0 \times 10^{-3}$ , Kvmax $6.8 \times 10^{-3}$	Low flow needle valve, fine
NV-02	Kvmin $5.6 \times 10^{-3}$ , Kvmax $5.6 \times 10^{-2}$	High flow needle valve, coarse

### 2.13.8 Pneumatic operated shut off valves NC or NO

The actuating pressure has to be supplied with a 3/2 way valve.

When the valve is not actuated the air actuation input has to vent.

Actuation pressure :

Minimal : 3 bar(g).

Maximal : 9 bar(g).

#### Removing

Ensure that the system is depressurised before taking the pneumatic shut off valve apart.

Remove the actuating pressure tubing and loosen the 4 bolts with hexagon head counter clockwise to release the valve.

#### Replacing

Replace the gasket AS-007 and AS-017, Viton (green), EPDM (purple) or Kalrez (black).

All wetted parts have to be absolutely clean, don't use oil or grease and avoid dust!

Replace the pneumatic shut off valve and tighten the bolts with hexagon head by turning clockwise, tighten crosswise with M3 1.1 Nm.

Replace the actuating pressure tubing.

Now the pneumatic shut off valve has to be tested for leakage and function.

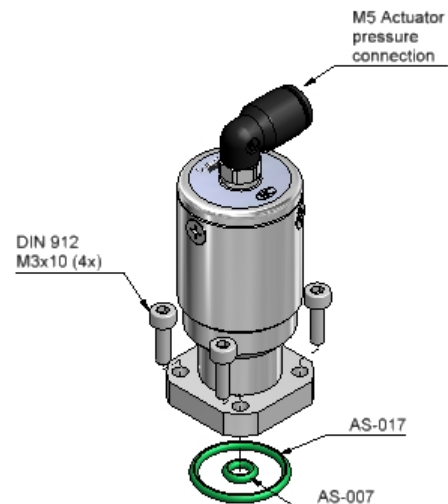

**Available Pneumatic shut off valves**

Model number	Description	
PV-01-NC-V	Kv=0,20	Normally Closed Viton
PV-01-NC-E	Kv=0,20	Normally Closed EPDM
PV-01-NC-K	Kv=0,20	Normally Closed Kalrez
PV-01-NO-V	Kv=0,20	Normally Open Viton
PV-01-NO-E	Kv=0,20	Normally Open EPDM
PV-01-NO-K	Kv=0,20	Normally Open Kalrez

**2.13.9 Pneumatic operated shut off 3/2 valves**

The actuating pressure has to be supplied with a 3/2 way valve. When the valve is not actuated the air actuation input has to vent.

Actuation pressure :

Minimal : 3 bar(g).  
Maximal : 9 bar(g).

**Removing**

Ensure that the system is depressurised before taking the pneumatic 3/2 valve apart.  
Remove the actuating pressure tubing loosen the 4 bolts with hexagon head counter clockwise to release the valve.

**Replacing**

Replace the gasket AS-007 and AS-017, Viton (green), EPDM (purple) or Kalrez (black).  
All wetted parts have to be absolutely clean, don't use oil or grease and avoid dust!  
Replace the pneumatic 3/2 valve and tighten the bolts with hexagon head by turning clockwise, tighten crosswise with M3 1.1 Nm.  
Replace the actuating pressure tubing.  
Now the pneumatic 3/2 valve has to be tested for leakage and function.

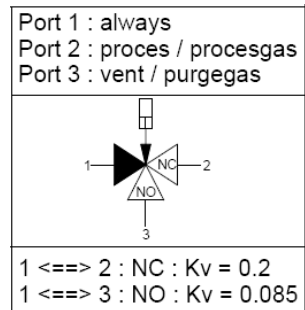
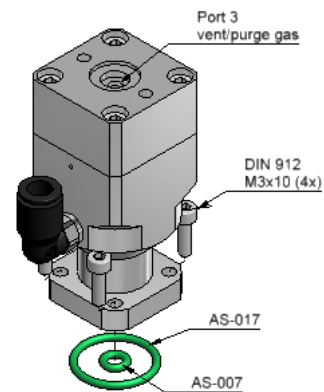

**Available Pneumatic operated 3/2 valves**

Model number	Description	
PV-32-V	NC : Kv=0,2 / NO : Kv=0.085	3/2 way Valve with Viton seals
PV-32-E	NC : Kv=0,2 / NO : Kv=0.085	3/2 way Valve with EPDM seals
PV-32-K	NC : Kv=0,2 / NO : Kv=0.085	3/2 way Valve with Kalrez seals

**2.13.10 Filter modules**

**Removal**

Ensure that the system is depressurised before taking filter apart.  
Remove the filter cup/cartridge assy by loosen the 4 bolts with hexagon head counter clockwise to release the assy.  
For disassembling the filter use a needle nose pliers place it in the bottom part and turn the part counter clockwise for release the filter.

**Replacement**

Replace the gaskets AS-007, AS-017 and when necessary AS-012, Viton (green), EPDM (purple) or Kalrez (black). When necessary replace the filter cup/cartridge. These can be ordered separately, because a dirty filter will cause extra pressure loss over the system. All wetted parts have to be absolutely clean, don't use oil or grease and avoid dust! Replace the filter and when necessary the AS-012 gasket. Tighten the bottom part hand tight into the cover. Place the gaskets and tighten the bolts with hexagon head by turning clockwise, tighten crosswise with M3 1.1 Nm. Now the filter has to be tested for leakage and function.

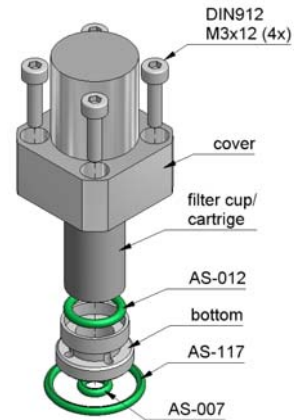

**Available Filter modules**

Model number	Description
	Element Pore Size [µm]
FF-01	0,5
FF-02	2
FF-03	7
FF-04	15

**2.13.11 Blind/Flow plates**

**Removal**

Ensure that the system is depressurised before dismantling the blind/flow plates. Remove the Blind/Flow plates assy by loosening the 4 bolts counter clockwise to release the assy.

**Replacement**

Replace the gaskets AS-105/AS-017 for the BP-01, AS-108/AS-115 for the BP-02, AS-017 for the FP-01 and AS-108/AS-115 for the FP-02; Viton (green), EPDM (purple) or Kalrez (black). All wetted parts have to be absolutely clean, don't use oil or grease and avoid dust! Replace the Blind/Flow plate and tighten the bolts by turning clockwise, tighten crosswise with M3 1.1 Nm for the Blind/Flow plate body valve/filter. For the Blind/Flow plate controller/meter with M4 2.6 Nm. Now the Blind/Flow plate has to be tested for leakage and function.

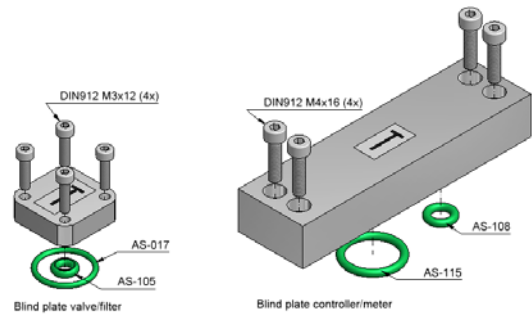

A **Flow plate** provides a flow path, in case where a module is removed temporarily or continuously from a Base Body for a valve/filter or a Base Body for a meter/controller.



A **Blind plate** blocks the flow, in case where a module is removed temporarily or continuously from a Base Body for a valve/filter or a Base Body for a meter/controller. In the Blind plate version for the valve/filter there is an O-ring AS-105 which can be removed when you want to use the plate as a Flow plate.



In the blind controller/meter version is an expander, which is pressed into the plate and can not be removed. In the flow version the expander is not present.

**Available Flow/Blind plates**

Model number		Description
Blind plate	Flow plate	
BP-01	FP-01	For valve/filter body
BP-02	FP-02	For meter/controller body

## 2.14 Model key

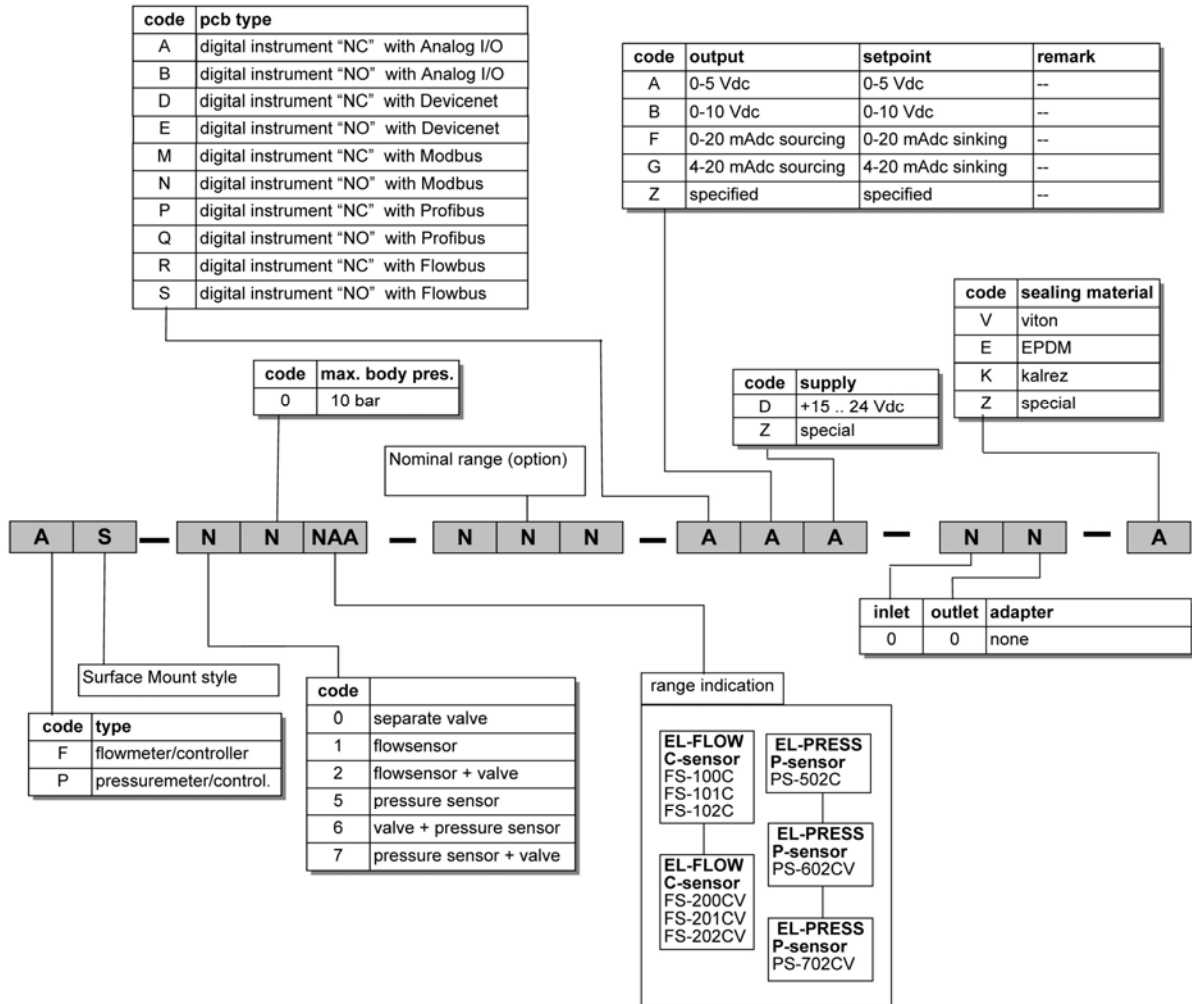

## 3 Basic operation

### 3.1 General

A FLOW-SMS instrument is equipped with a digital electronic 'Multibus' pc-board. These electronics consist of a micro-controller with peripheral circuitry for measuring, controlling and communication. The flow/pressure signal, is measured and digitized directly at the sensor and processed by means of the internal software (firmware).

Processed values can be measured and/or operated by means of:

- Analog interface (0...5 Vdc / 0...10 Vdc / 0...20 mA / 4...20 mA)
- Digital RS232 FLOW-BUS interface (connected to COM-port by means of special cable on 38400 Baud)
- Digital RS485 Modbus interface
- Digital Profibus interface
- Digital DeviceNet interface

Operation via analog or digital interface can be performed at the same time. A special parameter called "control mode" indicates to which setpoint the controller should respond.

### 3.2 Analog operation

At analog operation following signals are available:

- measured value (analog output)
- setpoint (analog input)
- valve voltage (controllers only)

The type of installed analog interface (0-5 V, 0-10 V, 0-20 mA or 4-20 mA) can be found in the model key of the instrument. Refer to paragraph 2.14.

Setpoints below 2% of the full scale will be interpreted as 0% setpoint.



*When operating the instrument through the analog interface it is possible to connect the instrument simultaneously to RS232 for reading/changing parameters (e.g. controller response or other fluid selection).*

### 3.3 Manual interface: micro-switch and LED's

By means of manual operation of the micro push-button switch some important actions for the instrument can be selected/started. These options are available in both analog and digital/fieldbus operation mode.

These functions are:

- reset (instrument firmware-program reset)
- restore factory settings (in case of unaccidently changing of the settings)

The LED's on top of the instrument can also be used for manual operation of some options. The green LED will indicate in what mode the instrument is active. The red LED will indicate error/warning situations.



*For details see "manual interface" in Operation Instructions Digital Instruments (document nr. 9.17.023, Chapter 10)*

### 3.4 Basic RS232 FLOW-BUS operation

Digital operation adds a lot of extra features (compared to analog operation) to the instruments.

Such as:

- setpoint slope (ramp function on setpoint for smooth control)
- 8 selectable fluids (calibration settings for high accuracy)
- direct reading at readout/control module or host computer
- testing and self diagnosis

- response alarm ( $|\text{setpoint-measure}|$  too high for too long time)
- several control/setpoint modes (e.g. purge/close valve)
- master/slave modes for ratio control (FLOW-BUS only)
- identification (serialnumber, modelnumber, device type, user tag)
- adjustable minimal and maximal alarm limits
- (batch) counter
- adjustable response time for controller when opening from zero
- adjustable response time for normal control
- adjustable response time for stable control ( $|\text{setpoint-measure}| < 2\%$ )



See 9.17.023 "Operation Instructions Digital Instruments" for more details about the parameters and properties of 'multibus' instruments.

RS232 FLOW-BUS communication can be used for operating your instrument using the Bronkhorst FlowDDE server application.



Physical layer and communication protocol are detected automatically upon reception of messages. These messages must be sent using the correct combination of physical layer and communication protocol. After every power-up the communication detection mode is active.

Dynamic Data Exchange (DDE) provides the user a basic level of inter process communication between Windows applications. FlowDDE is a DDE server application. Together with a client-application, either self-made or with a SCADA-program from 3rd-parties, it is possible to create an easy way of data exchange between the flow controller and a Windows application. For example, a cell in Microsoft Excel could be linked to the measured value of the flow controller and when the measured value changes, it will be automatically updated in the Excel spreadsheet.

Examples of DDE client applications: FlowPlot, FlowView, MS-Office, LabView, Intouch, Wizcon.

The FlowDDE server also offers a lot of test facilities and user adjustable settings for efficient communication with the connected flow/pressure meter or controller.

How to setup a DDE link with FlowDDE is described in the help-file of the FlowDDE application. Programming examples are available for making applications in: Visual Basic, LabView and Excel.

#### FlowDDE parameter numbers:

Reading/changing parameter values via FlowDDE offers the user a different interface to the instrument.

Besides the application name: 'FlowDDE' there is only need of:

- topic, used for channel number: 'C(X)'
- item, used for parameter number: 'P(Y)'

A DDE-parameter number is a unique number in a special FlowDDE instruments/parameter database and not the same as the parameter number from the process on an instrument.

Node-address and process number will be translated by FlowDDE to a channel number.



FlowDDE and other Bronkhorst applications are available at the Bronkhorst download site:  
<http://www.bronkhorst.com/en/downloads>



A special RS232 cable (7.03.366) can be ordered separately. It consists of a T-part with 1 male and 1 female sub-D 9 connector on one instrument-side and a normal female sub-D 9 connector on the side of the computer. By means of this cable it is possible to offer RS232 communication and still be able to connect power-supply and analog interface through the (analog) sub-D 9 connector.



RS232 communication is only possible with a baudrate of 38.4 Kbaud and can be used for either:

- Uploading new firmware by means of a special program (for trained BHT-service personnel only)
- Servicing your instrument using BHT-service programs (for trained BHT-service personnel only)
- Operating your instrument using FlowDDE, FLOWB32.DLL or RS232-ASCII protocol (end user)

### **3.5 Fieldbus operation**

Instructions for the range of optional fieldbus interfaces for digital Bronkhorst instruments are separately described in the following instruction manuals:



*'Multibus manuals'; see document numbers:*

*9.17.024 for FLOW-BUS*

*9.17.025 for PROFIBUS-DP*

*9.17.026 for DeviceNet*

*9.17.027 for RS232*

*9.17.035 for Modbus*

## 4 Advanced operation

### 4.1 Using mass flow meters/controllers on different gases or under different conditions

#### 4.1.1 Stored calibration curves

FLOW-SMS instruments with digital pc-boards allow storage of max. 8 calibration curves for various gases or process conditions. Fluidsets can digitally be selected when the instrument is hooked-up by RS232 to a computer, using (Bronkhorst) software tools.

#### 4.1.2 Multi Fluid / Multi Range instruments

Instruments with activated Multi Fluid / Multi Range (MFMR) functionality are calibrated for standard ranges which can easily be configured for other fluids and ranges. Changing fluid and range can be performed by means of the software tool FlowTune, through the RS232 connection of an instrument. The program can convert the primal calibration curve inside the instrument to the selected fluid and range.

In digital instruments with activated MFMR functionality the parameters capacity, density, unit type, capacity unit etc. are dynamic parameters. For example, changing the capacity unit from 'ml<sub>n</sub>/min' to 'l<sub>n</sub>/min' effects that the capacity automatically changes, for instance from 2000 ml<sub>n</sub>/min to 2 l<sub>n</sub>/min. The 100% output is not affected. Changing the capacity from 2000 ml<sub>n</sub>/min to 1000 ml<sub>n</sub>/min effects that the instruments full scale capacity (100% output) changes to 1000 ml<sub>n</sub>/min. The instrument is reranged.

#### 4.1.3 Conversion factor calculation using Fluidat software

Bronkhorst High-Tech B.V. gathered the physical properties of over 600 fluids in a database called FLUIDAT. Application software, such as FLOW CALCULATIONS, enables the user to calculate accurate conversion factors, not only at 20°C/1 atm but at any temperature/pressure combination, both for gases and for liquids. Apply to your distributor for more details of this software.



Check FLUIDAT® on <http://www.fluidat.com>

FLUIDAT® is a collection of routines to calculate physical properties of gases and liquids. These routines are made available at the FLUIDAT® on the Net website.

#### 4.1.4 Sealing material



Before using for a different fluid, check if the **sealing material** of the complete module like O-rings, plunger and packing gland of capillary are suitable for the application. The instrument is fitted with Viton, EPDM or Kalrez seals. Which sealing material is used is shown in the last character of the model key. It is also important to make sure that the seals of the mounting accessories (base block, adapters, etc.) are suitable for the fluids used (see schematic diagram /dimensional drawing).

#### 4.1.5 Maximum pressure drop

For solenoid operated control valves with small orifices the maximum allowable pressure drop for gases is according to the general table below. Please keep in mind that the pressure rating for FLOW-SMS is 10 bar only. The Kv value of the shut-off valves, in front of and behind the flow/pressure controllers, must be 1.5 times larger than total Kv value of the controllers. Otherwise the pressure drop over the shut-off valve will disturb the control performance.

Diameter [mm]	K <sub>v</sub>	Normally closed Δp max. [bard]	Normally opened Δp max. [bard]
0,05	4,33 x 10 <sup>-5</sup>	40	30
0,07	8,48 x 10 <sup>-5</sup>	30	20
0,10	1,73 x 10 <sup>-4</sup>	30	20
0,14	3,39 x 10 <sup>-4</sup>	30	20
0,20	6,93 x 10 <sup>-4</sup>	30	20
0,30	1,56 x 10 <sup>-3</sup>	30	20
0,37	2,37 x 10 <sup>-3</sup>	30	20
0,50	4,33 x 10 <sup>-3</sup>	30	20
0,70	8,48 x 10 <sup>-3</sup>	24	15
1,00	1,73 x 10 <sup>-2</sup>	12	8
1,30	2,93 x 10 <sup>-2</sup>	8	5
1,50	3,90 x 10 <sup>-2</sup>	6	n.a.
1,70	5,00 x 10 <sup>-2</sup>	5	n.a.
2,00	6,63 x 10 <sup>-2</sup>	3,6	n.a.

## 5 Troubleshooting and service

### 5.1 General

For a correct analysis of the proper operation of a flow/pressure meter or controller it is recommended to remove the unit from the process line and check it without applying fluid supply pressure. In case the unit is dirty, this can be ascertained immediately by loosening the compression type couplings and, if applicable the flange on the inlet side.

Energizing or de-energizing of the instrument indicates whether there is an electronic failure. After that, fluid pressure is to be applied in order to check behaviour. If there should be suspicion of leakage in case of a gas unit, do not check for bubbles with a leak detection liquid under the cover as this may lead to a short-circuit in the sensor or p.c.board.

### 5.2 LED indication

The red LED on the instrument gives error or warning information.

● Red LED	Time	Indication
Off	Continuously	No error
Flash	Variable	Bus activity on the Modbus interface
On	Continuously	Critical error message A serious error occurred in the instrument Instrument needs service before further using



For more information check the instruction manuals for digital communication/interfaces at [http://www.bronkhorst.com/en/downloads/instruction\\_manuals/](http://www.bronkhorst.com/en/downloads/instruction_manuals/)

### 5.3 Troubleshooting summary general

Symptom	Possible cause	Action
No output signal	No power supply	Check power supply and hook-up
		Check cable connection and hook-up.
		Check status of LED's (see manual 9.17.023 chapter 10)
	No setpoint	For analog used instruments measure between pin 3 and 8 of sub-D9 connector. For digital use make sure to perform a read setpoint after sending
	Cable damaged or hooked-up wrong	Check and compare signals at both ends of cable.
	PC-board damaged due to long lasting shortage and/or high-voltage peaks	Return to factory
	No or too low inlet pressure	Increase inlet pressure
		Open shut-off at inlet and outlet
	Supply pressure too high, or differential pressure across meter too high	Reduce supply pressure
	Valve blocked / contaminated	Set control mode to valve fully open and check if it opens
	Sensor / capillary failure	Return to factory
Maximum output signal	Leakage of control valve	Set control mode to valve close and check if it closes
	Sensor / capillary failure	Return to factory
Output signal much lower than setpoint signal or desired flow	Incorrect type of gas or too low inlet pressure	Test instrument on conditions for which it was designed
Oscillation	Supply pressure / diff. pressure too high	Reduce pressure
	Pressure regulator of supply pressure is oscillating or wrong sized	Replace pressure regulator
	Controller adjustment wrong	Adjust controller with PID settings
Flow is gradually decreasing	Condensation, can occur e.g. with NH <sub>3</sub>	Decrease supply pressure and / or heat gas to be measured
Small flow at zero setpoint	Valve leaks due to damage or dirt	Return to factory
	Increased zero reading without flow caused by raised zero-point	Perform an auto-zero action
No digital communication	Occupied or wrong bus address	Change address with software or rotary-switches
	No or wrong bus termination	Check cabling and termination

## 5.4 Service

For current information on Bronkhorst High-Tech and service addresses please visit our website:

 <http://www.bronkhorst.com>

Do you have any questions about our products? Our Sales Department will gladly assist you selecting the right product for your application. Contact sales by e-mail:

 [sales@bronkhorst.com](mailto:sales@bronkhorst.com)

For after-sales questions, our Customer Service Department is available with help and guidance. To contact CSD by e-mail:

 [support@bronkhorst.com](mailto:support@bronkhorst.com)

No matter the time zone, our experts within the Support Group are available to answer your request immediately or ensure appropriate further action. Our experts can be reached at:

 **+31 573 45 88 39**

## 6 Removal and return instructions

Instrument handlings:

- Purge gas lines
- Remove instrument from line
- Insert the instrument into a plastic bag and seal the bag
- Place the bag in a appropriate shipping container

Add documentation:

- Reason of return
- Failure symptoms
- Contaminated condition
- Declaration on Contamination form: 9.17.032

When returning material, always describe the problem and if possible the work to be done, in a covering letter.

**It is absolutely required to notify the factory if toxic or dangerous fluids have been metered with the instrument!**

This to enable the factory to take sufficient precautionary measures to safeguard the staff in their repair department. Take proper care of packing, if possible use the original packing box; seal instrument in plastic, etc.

**Contaminated instruments must be dispatched with a completely filled in 'declaration on contamination form'.  
Contaminated instruments without this declaration will not be accepted.**

**Note:**

If the instruments have been used with toxic or dangerous fluids the customer should pre-clean the instrument.

**Important:**

Clearly note, on top of the package, the customer clearance number of Bronkhorst High-Tech B.V., namely:  
NL801989978B01

If applicable, otherwise contact your distributor for local arrangements.



*The declaration on contamination form is available at the Bronkhorst download site:  
[http://www.bronkhorst.com/en/downloads/safety\\_information\\_for\\_returns.pdf](http://www.bronkhorst.com/en/downloads/safety_information_for_returns.pdf)*