

# A111 - AN03 - GASZUFUHR FÜR INDUKTIV GEKOPPELTES PLASMA (ICP-AES)

---

APPLICATION NOTE A111-AN03

## CONTROLLED SUPPLY OF GASES IN INDUCTIVELY COUPLED PLASMA (ICP-AES) FOR ENVIRONMENTAL ANALYSIS

**How can a municipality determine if the soil of a piece of land is clean enough for district development to take place, so that new houses can be built? And which contaminants are present in surface water, seawater or fishing water, if you would like to find out if it is safe for human drinking purposes or for fish to swim in?**

One way to determine the concentration of trace metals and other elements in our environment is by using ICP-AES. This elemental analysis technique makes use of an **inductively coupled plasma** (ICP) to generate excited ions and atoms, whose characteristic spectrum is measured by **atomic emission spectrometry** (AES) when they relax to the ground state. The intensity of the spectrum lines is a direct measure of an element's concentration, which can go down to ppb (parts per billion) range.

Bronkhorst closely cooperates with a major ICP-AES equipment manufacturer. For the plasma part, as well as for the optical part, mass flow meters or flow controllers and other devices are used for inert gases to be supplied.



---

### Application requirements

The plasma section of the ICP-AES needs an accurate, reproducible gas flow, whereas for the optical section, the required purge gas flow needs to be reproducible. Furthermore, the gas delivery device needs to be compact, with preferably a cost price as low as possible.

### Important topics

- Elemental analysis
  - Accuracy combined with reproducibility
  - Cost reduction
  - Small footprint
-

## Process solution

The Bronkhorst solution is a compact manifold consisting of a mass flow meter or flow controller part for the plasma section of the ICP-AES, and a purge part to serve the optical section. Through one of the three thermal mass flow controllers, an argon gas flow enters the nebulizer of the ICP-AES for turning the to-be-analysed sample into a mist. The other two mass flow controllers allow argon to enter the induction-coil surrounded reactor to be turned into a plasma, and for auxiliary purposes. The thermal mass flow controllers generate accurate, reproducible flows in the range of 1.5 litre per minute to 20 litres per minute. This accuracy is necessary for the contents inside the reactor to have a correct composition.

The Bronkhorst mass flow controllers are controlled by the lab equipment. However, the Bronkhorst devices contain a printed circuit board with specific settings ('firmware'), to be able to communicate more easily with the ICP-AES.

The purge part of the manifold consists of orifices combined with a pressure regulator to control the desired pre-pressure. Nitrogen gas flows, in the range from 0.2 liter per minute to 7 liters per minute, are used to purge the optical section of the ICP-AES, in order to guide away gases that might disturb the emission measurement process.

In the starting years of ICP, the supply of gases was controlled manually. When automation has made its way into this field, also the control of gases was not spared, and mass flow controllers have been introduced. Such a good gas flow control has resulted in an increase in accuracy and stability, and lower detection limits became possible - which is a good point in meeting increasingly stringent environmental requirements.

The manifold is designed for an optimum value/price combination. Cost reduction is a driver in this market, and from the manufacturer's perspective one single supplier for gas related issues is favourable. A compact device has a small footprint, which is important due to the limited space in the lab. The small size of Bronkhorst mass flow controllers is useful here.

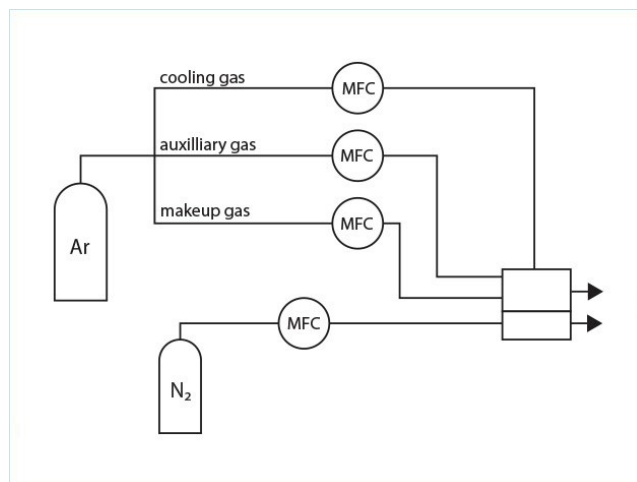

Flow scheme

## Recommended Products



### MANI-FLOW

Kompakte Größe sorgt für gute Raumeffizienz  
Kostengünstige Lösung, geringe Betriebskosten  
Kombination von Funktionen auf einem Verteilerblock



### IQ+FLOW IQF-200C MFC

Min. Bereich 0...10 mln/min  
Max. Bereich 0...5 ln/min  
Druckstufe 10 bar  
Ultrakompakt  
MEMS Technologie

**BRONKHORST DEUTSCHLAND NORD GMBH**

Südfeld 1b

59174 Kamen (GER)

Tel. [+49 230792512-0](tel:+49230792512-0)

[info@bronkhorst-nord.de](mailto:info@bronkhorst-nord.de)



**Diese Webseite verwendet Cookies**

Wir verwenden Cookies, um Inhalte und Anzeigen zu personalisieren, Funktionen für soziale Medien anbieten zu können und die Zugriffe auf unsere Website zu analysieren. Außerdem geben wir Informationen zu Ihrer Verwendung unserer Website an unsere Partner für soziale Medien, Werbung und Analysen weiter. Unsere Partner führen diese Informationen möglicherweise mit weiteren Daten zusammen, die Sie ihnen bereitgestellt haben oder die sie im Rahmen Ihrer Nutzung der Dienste gesammelt haben. Sie geben Einwilligung zu unseren Cookies, wenn Sie unsere Webseite weiterhin nutzen.

Notwendig

Präferenzen

Statistiken

Marketing

Details zeigen

OK

