

DATASHEET A088-EN04 - PASSIVIERUNGSSCHICHTEN FÜR SOLARMODULE

APPLICATION NOTE A088-EN04

Thin aluminium oxide passivation layers for solar cells

Our world is increasingly relying on sustainable energy such as wind and solar power. This poses the question: how can the sunlight-to-electricity efficiency of photovoltaic (PV) solar cells be improved any further? Physics dictate that the efficiency of extensively used crystalline silicon-based solar cells cannot exceed 29%. In practice, the maximum efficiency for these cells is about 21 to 22% nowadays, so there is room for improvement.

One way to increase the efficiency is by diminishing the losses that are present in the energy conversion processes inside the solar cell. Passivation layers are able to prevent unwanted premature recombination of electrons and electron holes within the silicon, allowing these charged particles to leave the solar cell and do their 'power generating' job. Bronkhorst equipment is involved in applying thin aluminium oxide passivation layers.

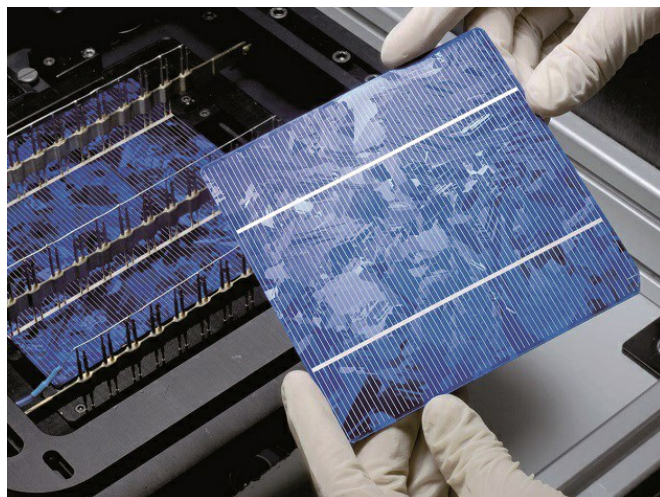

Application requirements

The aluminium oxide deposition process inside a vacuum reactor using oxygen and trimethylaluminium (TMA) as precursor is highly sensitive, and needs to occur under very dry and clean conditions, to prevent premature reaction of TMA. To this end, the argon carrier gas needs to be very pure - grade 6.0 or better. Moreover, accuracy and reproducibility of the supplied chemical compounds is essential when applying ultrathin layers in the nanometer range.

Important topics

- Accurate supply of gaseous and vaporous reactants
 - Repeatability
 - Stable system
-

Process solution

The aluminium oxide passivation layer is deposited by a reaction of trimethylaluminium (TMA) with oxygen. TMA is supplied as a liquid, but for the process it has to be a vapour, and for this reason a Bronkhorst CEM system (Controlled Evaporation & Mixing) is used. Oxygen is supplied using a Bronkhorst EL-FLOW thermal mass flow controller, that reacts at the surface of the substrate with TMA vapour and deposits as a thin aluminium oxide layer.

An advantage of a 'simple' bubbler to generate a vapour is, indeed, its simple setup. However, a CEM system outperforms a bubbler in many ways. As the temperature distribution inside this device is much more controlled, the vapour supply - so the amount of TMA vapour that is being carried along by an argon carrier gas - is much more accurate and reproducible. This results in a stable quality of the deposited layer over time.

In addition to preventing unwanted premature recombination of electrons and holes, the aluminium oxide passivation layer acts as a mirror that reflects sunlight, so that it re-enters the active part of the solar cell in order to be converted to electricity, increasing the efficiency even more. By applying an aluminium oxide passivation layer, the efficiency of the solar cell increases from 21-22% to about 23.5%.

This coating system works very stable. In fact, this CEM system anticipates to the expectation that liquid precursors will become more important in this type of deposition processes. It may also be interesting for the semiconductor industry, to apply a very thin passivation layer that prevents unwanted interactions between the tiny structures.

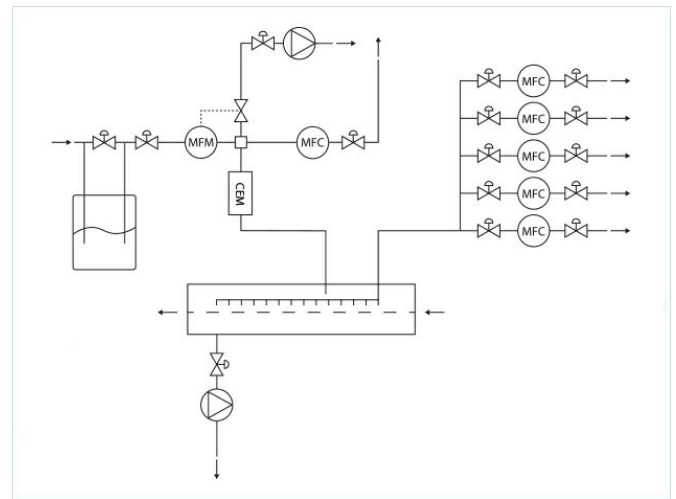

Flow scheme

Recommended Products



CEM EVAPORATOR W-202A

Max. 120 g/h Flüssigkeit;
Max. 10 l/min Gas
Druckstufe 100 bar
Sehr stabiler Dampf-
Durchfluss
Flexibles Gas-
/Flüssigkeits Verhältnis



EL-FLOW SELECT F-201CV

Min. Bereich 0,16...8
mln/min
Max. Bereich 0,5...25
l/min
Druckstufe 64 bar
Kompakte Bauweise
Hohe Genauigkeit
& Wiederholgenauigkeit



LIQUI-FLOW™ L13

Min. Bereich 0,25 ... 5 g/h
Max. Bereich 5 ... 100 g/h
Druckstufe 100 bar
kompaktes, IP40 Design
Analoge, RS232 oder
Feldbus I/O



MINI CORI-FLOW™ M12

Durchfluss 0...200 g/h
Druckstufe 200 bar
Medienunabhängig
Hohe Genauigkeit,
schnelle Messung



Bronkhorst High-Tech designs and manufactures innovative instruments and subsystems for low-flow measurement and control for use in laboratories, machinery and industry. Driven by a strong sense of sustainability and with many years of experience, we offer an extensive range of (mass) flow meters and controllers for gases and liquids, based on thermal, Coriolis and ultrasonic measuring principles. Our global sales and service network provides local support in more than 40 countries. Discover Bronkhorst[®]!