

APPLICATION NOTE

Flow control for optimising growth of microorganisms

A German research institute asked Bronkhorst Deutschland Nord for support supplying them a **liquid flow control setup** to be used in research to learn more about the conditions under which a population of microorganisms is able to grow using varying parameters. Flow control is used for an **accurate** and **steady** flow of aqueous liquid.

Today, more than ever, enzymes and microorganisms are being used to increase the sustainable production of pharmaceuticals and (bio)chemicals. Researchers in institutes or the industry want to know under which conditions these biological cells grow faster or slower and want to learn about the influence of nutrients or additives to understand the underlying biological processes.



Application requirements

To investigate under which conditions a population of microorganisms is able to grow when varying one typical parameter, the other parameters such as temperature, pressure and nutrient concentration need to be kept constant. To that end, the liquid levels of two reactor vessels containing these microorganisms need to be accurately kept at a stable, constant value using flow control.

Important topics

- Accurate, steady flow of aqueous liquid using direct flow control
- Stable liquid level to support microorganism growth

Process solution

Bronkhorst supplied two liquid mass flow instruments (series mini CORI-FLOW). Each of them inserted in the circulation system in between the reactor vessels, with the aim to provide a continuous flow of aqueous liquid.

The researchers allowed the micro-organisms to grow in the main reactor of approx. 1 liter in an aqueous environment. For determining the cell growth rate, they took samples from the main reactor at regular intervals. Temperature is an important parameter. Too low temperatures will refrain microorganisms from growing, and too high temperatures are detrimental to the microorganisms themselves.

The liquid mass flow instrument with (CSI) control valve gives a signal to a control unit which controls a pump, creating a 'direct pump control'. The liquid goes from the main reactor to a second reactor with a volume of about 200 ml, and from there it will be pumped with a second flow controller/pump combination back to the main reactor. It is a continuous circulation, day and night, which should go steady.

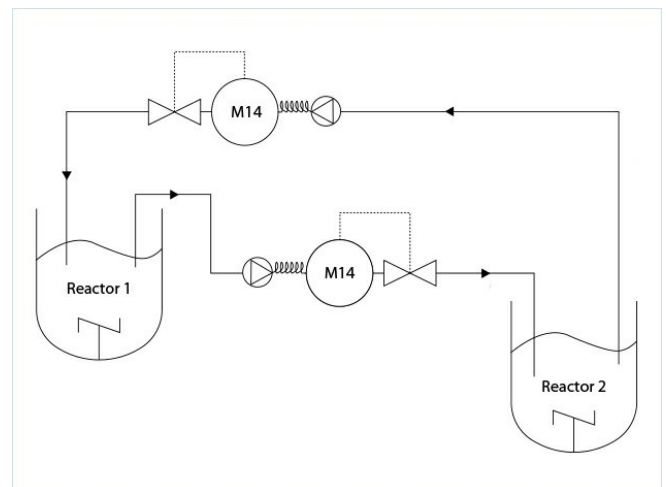

Flow scheme

As both flow controller/pump combinations have the same capacities, the levels in both reactors remain at the same, stable value. The setpoints are established by a control unit of the research institute.

Before contacting Bronkhorst, the research institute struggled to stabilize the low aqueous stream - in the range of 30 to 200 ml/min - without emptying one of the reactors. In order to keep the 3 µm sized microorganisms alive and without any damage during the circulation, Bronkhorst advised to use peristaltic hose pumps.

E-Book: How to handle low liquid flows

Do you want to learn more about how to handle low liquid flows (< 100 g/h)?

Download our e-book to find out more about 'low flows'. Including in-depth information, technical advice and insider tips from our experts.

Recommended Products



MINI CORI-FLOW™ MXX

Min. Bereich 0,05...5 ml/h
Max. Bereich 3...300 l/h
Druckstufe bis zu 200 bar
Hohe Genauigkeit, schnelle Messung
Dichte und Temperaturansicht



SERIES C2I, C5I

Durchflussventile für Flüssigkeiten

Direktwirkendes Ventil
Druckstufe 64/100 bar
Kv-max: 6.6×10^{-2}



MINI CORI-FLOW™ CORIOLIS WITH PUMP

Min. flow 0,05...5 ml/h
Max. flow 6...600 l/h
Compact, integrated dosing solution
Direct pump control



BRONKHORST DEUTSCHLAND NORD GMBH

Südfeld 1b

59174 Kamen (GER)

Tel. +49 230792512-0

info@bronkhorst-nord.de



Diese Webseite verwendet Cookies

Wir verwenden Cookies, um Inhalte und Anzeigen zu personalisieren, Funktionen für soziale Medien anbieten zu können und die Zugriffe auf unsere Website zu analysieren. Außerdem geben wir Informationen zu Ihrer Verwendung unserer Website an unsere Partner für soziale Medien, Werbung und Analysen weiter. Unsere Partner führen diese Informationen möglicherweise mit weiteren Daten zusammen, die Sie ihnen bereitgestellt haben oder die sie im Rahmen Ihrer Nutzung der Dienste gesammelt haben. Sie geben Einwilligung zu unseren Cookies, wenn Sie unsere Webseite weiterhin nutzen.

Notwendig Präferenzen Statistiken Marketing Details zeigen

OK

