

MICRO REACTOR TECHNOLOGY

Due to the needs for higher yields, enhanced efficiency, improved safety and minimized environmental risk, nowadays the Pharmaceutical Industry seeks alternatives to the conventional batch reactors; therefore, the industry trend is to adopt micro reactors as an alternative method especially for organic synthesis of extremely exothermic (im)miscible fluids.

Aware of these demands, Bronkhorst has successfully developed innovative solutions dedicated to meet Micro Reactor Technology standards.

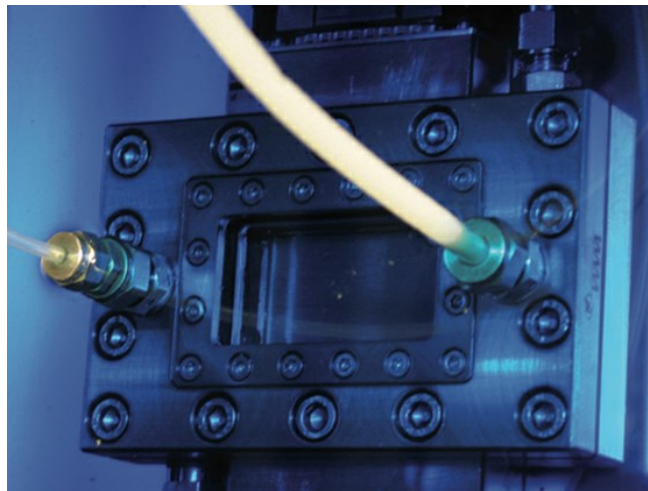

Micro reactor

Application requirements

Pilot process development requires new generation liquid dosing systems of direct mass flow measurement/control. Such systems must be highly stable (very low pulsation in flow) and highly accurate.

The dosing unit should be a plug and play component (pump controlled by a mass flow instrument) with the possibility to adjust PID setting.

Important topics

- Easy to use
- No need to pressurise liquid source
- Direct mass flow measurement control
- Mass and volume dosage possible

Process solution

Micro reactors are continuous reactors with extremely small physical size. These configurations are used to enhance the surface-to-volume ratio hence to improve heat transfer and increase selectivity. Such sizes are suitable for pilot scale reactions but this solution can be transposed to production scale capacity as well by combining multiple reactors operating parallel to each other.

Due to its features these alternative reactors are very convenient, because a superior control and optimal use of reagents is achieved. Since all the process takes place in a closed system, toxic, hazardous or explosive chemicals can be used without raising severe safety and environmental issues. Given that the micro reactors have exceptionally small sizes, extremely subtle flows are involved, thus to achieve an optimal process, appropriate peripheral flow controllers and dosing systems will be required. One of the solutions developed by Bronkhorst involves the use of our unique flow sensor of the LIQUI-FLOW or CORI-FLOW series with controlling function, a gear pump, a filter, a check valve and all interconnecting material. The advantage of this setup is the possibility to have a stable and accurate liquid flow without gas bubbles. Additionally the system is suitable for several dissimilar liquids due to the Coriolis measuring principle.

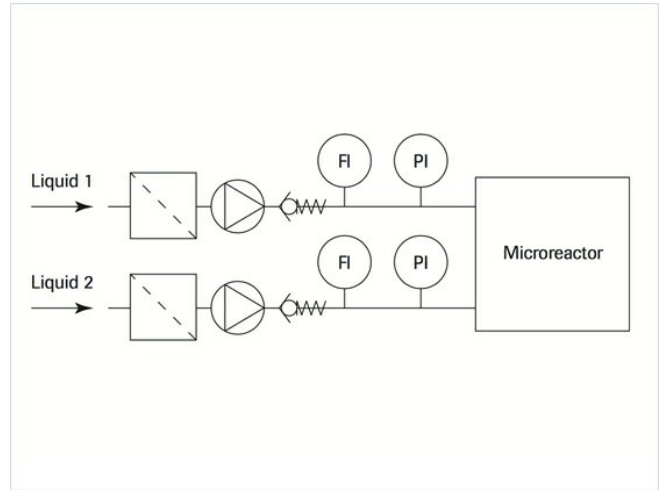

A schematic technical diagram showing our product included in the customer's process

Recommended Products



MINI CORI-FLOW™ M14

Min. flow 0,03...1 kg/h
Max. flow 0,3...30 kg/h
Pressure rating 200 bar
Independent of fluid properties
High accuracy, fast response



EL-PRESS P-502C

Min. pressure 2...100 mbar
Max. pressure 1,28...64 bar
Absolute or gauge pressure
High accuracy

Would you like to know more?

Stay up to date with the latest developments in high tech with our newsletter.



BRONKHORST (UK) LTD

1 Kings Court

Willie Snaith Road

Newmarket Suffolk CB8 7TG

Tel. [+44 1223 833222](tel:+441223833222)

sales@bronkhorst.co.uk