

# APPLICATION NOTE A054-ME09 SIMULATION OF HIGH ALTITUDE ENVIRONMENT

---

APPLICATION NOTE A054-ME09

## SIMULATION OF HIGH ALTITUDE ENVIRONMENT

**As humans, we perform at our best by an atmospheric pressure that contains about 21% oxygen. As a result, a lower oxygen pressure has some detrimental mental and physical effects. These effects mainly manifest at high altitudes with a low total pressure. This phenomenon is known as hypoxia.**

A government department investigates hypoxia and places human test subjects in a low-pressure chamber, under medical supervision. The conditions at high altitude are simulated by lowering the absolute pressure to a value that equals the specific altitude, but it is rather harsh for the body. Moreover, as the CO<sub>2</sub> level inside the human body is a major regulator of respiration, one line of investigation is by adding CO<sub>2</sub> to artificial breathing air at atmospheric conditions. The latter is difficult to implement at low pressure. Bronkhorst was able to realise a solution in cooperation with a system integrating company.



Photo: Sheppard Air Force Base

---

### Application requirements

As an alternative for the low-pressure chamber, a solution has to be found at atmospheric pressure where well-defined gas mixtures can be supplied. So air constituents such as oxygen, nitrogen and carbon dioxide have to be supplied independently from each other to a human test subject.

This supply has to be conducted in an accurate, repeatable and well-controlled way, to be sure that the desired N<sub>2</sub>/O<sub>2</sub>/CO<sub>2</sub> mixture really has been supplied. Furthermore, a possibility to document the test conditions and results is required.

### Important topics

- Accurate dosing of air constituents
  - Documentation of test conditions
  - Repeatability
  - Compact system
-

## Process solution

Bronkhorst delivered three thermal mass flow controllers for accurately supplying nitrogen, oxygen and carbon dioxide. The system integrating company placed these controllers together with a gas mixing chamber and the controlling & monitoring (PLC) system in a compact box. During operation, the gas mixture was supplied to the human test subject via a mask that covered both nose and mouth. In this way, a complete solution has been realised for the government department. Using this setup, which works at atmospheric pressure, human test subjects no longer have to be subjected to low total pressures, making it easy for the human body, and carbon dioxide can be supplied in various contents as a constituent of artificial breathing air.

The control unit can be configured to deliver any desired mixture of nitrogen, oxygen and carbon dioxide. The setup allows an accurate analysis of specific gas mixture concentrations, and tests have demonstrated that is done in a repeatable way. Furthermore, under different circumstances - i.e. the equivalent of several altitudes, including sea level - reproducible results can be obtained. Using this system, the process is easily monitored and relevant data such as the actual delivered gas mixture are well documented.

Based on these results, Bronkhorst and the system integrating company actually met the targets set. This was also due to the high flexibility of the system and its low initial costs. Due to this success, the government department is evaluating additional systems for similar tests in different locations.

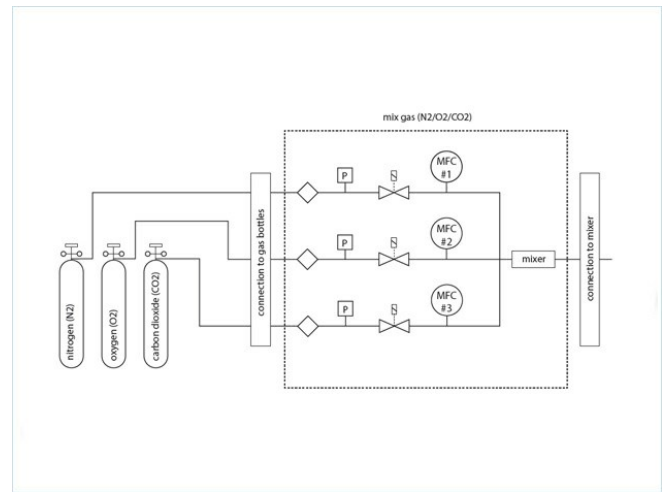

Flow scheme

**Would you like more information about thermal mass flow?**

---

---

## Recommended Products



### EL-FLOW SELECT F-201CV

Min. flow 0,16...8 mln/min  
Max. flow 0,5...25 ln/min  
Pressure rating 64 bar  
Compact design  
High accuracy and repeatability

## Would you like to know more?

Stay up to date with the latest developments in high tech with our newsletter.



**BRONKHORST (UK) LTD**

1 Kings Court

Willie Snaith Road

Newmarket Suffolk CB8 7TG

Tel. [+44 1223 833222](tel:+441223833222)

[sales@bronkhorst.co.uk](mailto:sales@bronkhorst.co.uk)

