

# DATASHEET FLOW CONTROL IN BURNER AND FURNACE APPLICATIONS A061

---

## APPLICATION NOTE

### Flow Control in Burner & Furnace applications

- for combustion processes -

Oxy-fuel combustion processes are frequently used in surface treatment applications like re-burning, or glass polishing. Oxy-fuel combustion is a combustion process using pure oxygen as an oxidiser instead of Air. By excluding nitrogen from the combustion process, the flame temperature increases significantly. This results in less smoke and a limitation of NOx production.

Mass flow control is an effective solution to control and manage the gas supply in burner and furnace applications. Recognising the requirements of oxy-fuel combustion processes, Bronkhorst has developed a full product line of [gas flow instruments](#) for such applications.



---

#### Application requirements

In these combustion processes, the result depends mainly on the quality and consistency of the burner flame. The flame is produced with a gas mixture of oxidant (O<sub>2</sub>) and fuel (natural gas) from all burners of the production line. It is therefore essential to supply a constant quantity of gas, thus preventing the flame from going out, and to ensure a constant and homogeneous gas mixture.

Maintenance costs must be minimised, and the risk of production stops must be reduced. The use of [gas flow meters](#) also reduces the previous reliance on the operator's skills to manually set the required gas flows.

#### Optional features

- Stability of the gas mixture
  - Reduction of exhaust fumes and NOx emissions
  - Robustness
-

## Process solution

The solution provided by Bronkhorst can be compared to a pressure control; two gas mass flow controllers for each burner – one for the fuel (methane, propane, or acetylene) and one for the oxidant (air or oxygen in the case of oxy-fuel combustion) – will be combined.

The flow controller from the MASS-STREAM series has a robust IP65 rated housing, making it ideal for dusty and hot conditions. These instruments are less sensitive to contamination rather than traditional mass flow meters because its measuring element is in the main gas stream.

To achieve an ideal combustion, it is crucial to accurately control the amount of gas injected.

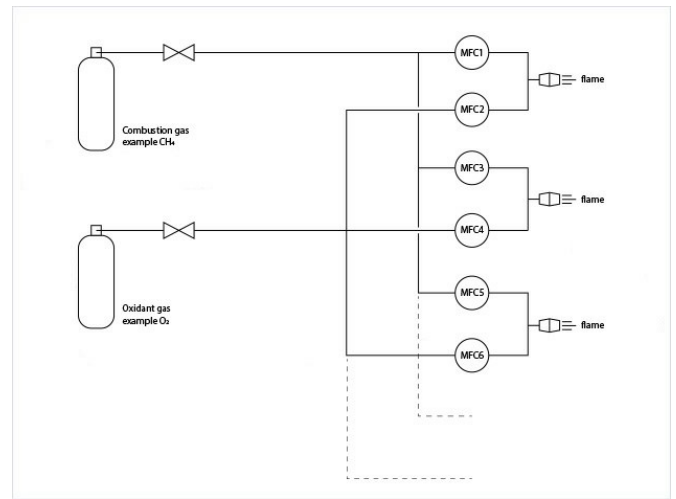

Schematic drawing

## How can you benefit from MASS-STREAM flow controllers?

The thermal mass flow technology used for the MASS STREAM series, allows the measurement and control of flow rates independent of pressure and temperature conditions. This eliminates the need to install an expensive pressure reducing valve upstream of the process to stabilise the pressure. In addition, if the burner starts to clog and generate back pressure, the combination of flow meter, valve and control loop will compensate for this back pressure by acting on the valve opening of the instruments, thus maintaining process stability. This action on the valve can be followed on a data acquisition system and allows prevention and limitation of production stops.

A local control function on the instrument itself is possible when the device is equipped with the optional integrated display and its operator buttons. It can also be connected to a PLC for a command control or to an acquisition system to ensure the follow-up of the process.



**Would you like advice on how flow meters can help you optimise your burner & furnace application?**

## Recommended Products



**MASS-STREAM D-6341 & D-6441 MFC**

Min. flow 0,14...7 l/min  
Max. flow 1...50 l/min  
Pressure rating up to 20 bar  
Rugged sensor and housing (IP65)  
Optional integrated TFT display



**MASS-STREAM D-6471/DR3 MFC**

Min. flow 6...300 l/min  
Max. flow 60...3000 l/min  
For Low-ΔP applications  
Pressure rating up to 5 bar  
Optional integrated TFT display



**MASS-STREAM D-6371/004BI & D-6471/004BI MFC**

Min. flow 2...100 l/min  
Max. flow 20...1000 l/min  
Pressure rating up to 10 bar  
Rugged sensor and housing (IP65)  
Optional integrated TFT display



**MASS-STREAM D-6371A/003AI & D-6471A/003AI MFC**

Min. flow 4...200 l/min  
Max. flow 40...2000 l/min  
Pressure rating up to 20 bar  
Rugged sensor and housing (IP65)  
Optional integrated TFT display