

# APPLICATION NOTE A081-GP03 - GAS SUPPLY CONTROL IN STATIONARY NATURAL GAS ENGINES

---

APPLICATION NOTE A081-GP03

## GAS SUPPLY CONTROL IN STATIONARY NATURAL GAS ENGINES

**In stationary natural gas engines, natural gas is being combusted with air with the aim to exploit the combustion energy, for example for combined heat and power generation (CHP). These engines are flexible in the sense that they can be switched on rather quickly when their energy is required, at a power failure or to 'step in' at peak periods. Although the emission of nitrogen oxides (NO<sub>x</sub>) as by-product of the combustion in these engines is relatively low, it can be decreased even further by using exhaust gas recirculation, which reduces the combustion temperature and, hence, the NO<sub>x</sub> emission. Furthermore, hydrogen can be added to the combustion process to improve its ignition and flame speed.**

To investigate the influence of hydrogen and exhaust gas recirculation components on this type of engine, Bronkhorst was asked to deliver a mass flow meter and several mass flow controllers for this specific gas types.

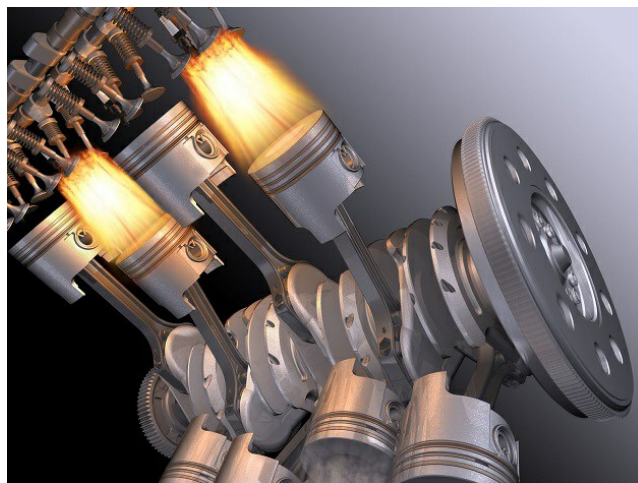

Combustion inside a V8 engine

---

### Application requirements

A pre-set ratio of a simulated gas mixture of methane, hydrogen, nitrogen and carbon dioxide should be established fast and accurately in the combustion chamber of the engine. Methane is the main constituent of natural gas; nitrogen and carbon dioxide act as artificial exhaust gas recirculation components. Furthermore, the mass flow of each of these components has to be logged.

### Important topics

- Fast and accurate flow control of CH<sub>4</sub>, H<sub>2</sub>, N<sub>2</sub> and CO<sub>2</sub>
  - Logging of mass flow of each of these components
-

## Process solution

Bronkhorst delivered one EL-FLOW Select mass flow meter and three EL-FLOW Select mass flow controllers, together with their power supply, read-out and control equipment, to a stationary natural gas engine test bench.

In this test bench, to simulate the natural gas combustion process with hydrogen and exhaust gas recirculation components added, main component methane ( $\text{CH}_4$ ) is mixed together with additional components hydrogen ( $\text{H}_2$ ), nitrogen ( $\text{N}_2$ ) and carbon dioxide ( $\text{CO}_2$ ). A master/slave configuration is used here. The additional components  $\text{H}_2$ ,  $\text{N}_2$  and  $\text{CO}_2$  are supplied by three Bronkhorst mass flow controllers ('slaves'), of which the flows depend on the  $\text{CH}_4$  flow ('master'). The operator can set the relative mass flows of  $\text{H}_2$ ,  $\text{N}_2$  and  $\text{CO}_2$  via the RS232 communication protocol. The  $\text{CH}_4$  flow is measured by the Bronkhorst mass flow meter, and the total fuel mass flow is controlled via the lambda air-fuel ratio controller of the engine.

The data with respect to the mass flows of each of the component are logged using a MATLAB/Simulink interface. In this test bench, many signals are being logged, ranging from operational temperatures to emission concentrations in the exhaust gas. Most signals are available as CAN (Controller Area Network) messages.

The people investigating the combustion process are very satisfied with the way the Bronkhorst devices perform, especially with respect to the master/slave functionality. The  $\text{H}_2$ ,  $\text{CO}_2$  and  $\text{N}_2$  mass flows are adjusted exactly as desired using this setup.

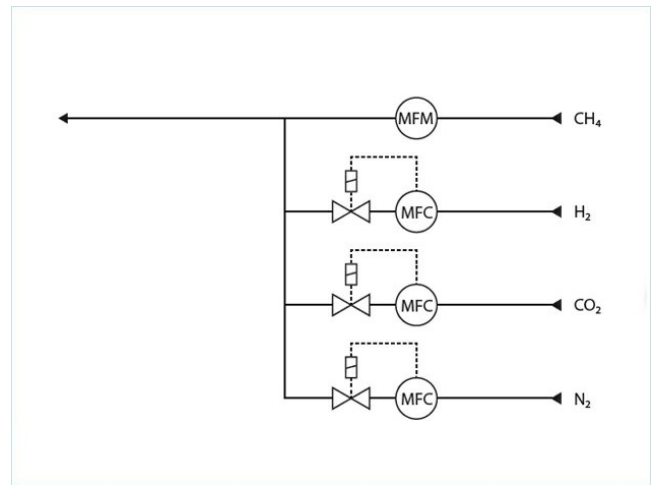

Flow scheme

## Recommended Products



EL-FLOW SELECT F-201CV

Min. flow 0,16...8 ml/min  
Max. flow 0,5...25 l/min  
Pressure rating 64 bar  
Compact design  
High accuracy and repeatability



EL-FLOW SELECT F-111B

Min. flow 0,16...8 ml/min  
Max. flow 0,16...25 l/min  
Pressure rating 100 bar  
Compact design  
High accuracy



E-8000 SERIES

### Digital Readout / Control Systems

Bright, wide angle, 1.8" display (TFT technology)  
User friendly operation, menu driven with 4 push buttons



**BRONKHORST USA INC.**

57 South Commerce Way

Suite 120

USA - Bethlehem, PA 18017

Tel. [+1-610-866-6750](tel:+1-610-866-6750)

[sales@bronkhorstusa.com](mailto:sales@bronkhorstusa.com)