

APPLICATION NOTE A089-GP99 - CONTROLLED SUPPLY OF OXYGEN FOR IRON REMOVAL IN DRINKING WATER PRODUCTION

APPLICATION NOTE A089-GP99

CONTROLLED SUPPLY OF OXYGEN FOR IRON REMOVAL IN DRINKING WATER PRODUCTION

Raw water that naturally occurs in aquifers in the earth's crust contains dissolved iron in the ferrous Fe^{2+} form. In waterworks that extract and purify water to make it suitable as drinking water, this iron has to be removed to a large extent - to prevent problems such as an unpleasant metallic taste when drinking, or rust stains in clothes when laundering.

Iron removal usually occurs through aeration of the water, for example using a cascade. Oxygen from the air reacts with Fe^{2+} to form solid iron hydroxide flocks that deposit or are removed by filtration. When conventional aeration is not sufficient to remove iron, additional oxygen has to be supplied to the water. Bronkhorst Deutschland Nord assisted a waterworks company in providing a flow solution for additional oxygen supply.



Application requirements

To keep the water quality of the waterworks company at a high level, a relatively simple solution has to be found without the use of any (expensive) chemical compounds. Especially when the raw water contains high concentrations of dissolved iron, conventional aeration using oxygen from the air may not be satisfactory and a pure oxygen supply is more suitable.

Important topics

- Oxygen gas supply proportional to water flow
 - Fast controlling solution
 - No other chemicals necessary
-

Process solution

The waterworks company has its own techniques to analyse whether or not the raw water flow requires any additional oxygen supply. If so, the flow through a water channel is measured and its signal is forwarded to a Bronkhorst E-8000 readout and control unit that transmits the set point value to the splash proof Bronkhorst IN-FLOW thermal mass flow controller. The oxygen mass flow is proportionally related to the flow in the water channel and has a value in the range of 10 to 133 normal liters of oxygen per minute.

The supplied oxygen is generated by air separation by means of pressure swing adsorption (PSA). A Bronkhorst EL-PRESS electronic pressure controller is used to set the pressure in a buffer tank prior to the mass flow controller. This device supplies the correct amount of oxygen to the water, about 10 to 133 l_n/min of O₂ is dosed, free of oil and grease.

Aeration - using oxygen from the air in the cascade configuration or additionally supplied - is a rather natural way to remove dissolved iron from raw water, so to oxidise ferrous Fe²⁺ to ferric Fe³⁺ as Fe(OH)₃, without the use of additional chemical compounds. This technique can also be applied to remove dissolved manganese from raw water to some extent. In the current application, the oxidised iron and manganese deposits on a sand or gravel filter, and is removed from the filter by backwashing.

The configuration as provided here can be a solution for waterworks companies that need additional water aeration, as well as for oxygen producing companies (e.g. by PSA) that need a controlled way to supply the produced oxygen in a wide range of mass flow or volume flow.

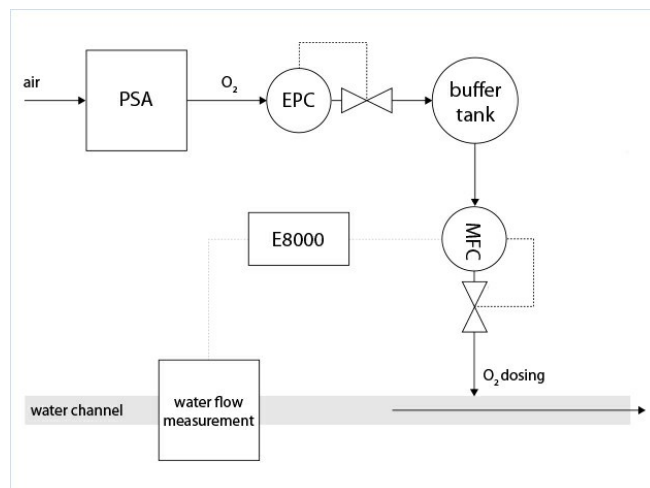

Flow scheme

Recommended Products



IN-FLOW F-202AI

Min. flow 0,8...40 l/min
Max. flow 5...250 l/min
Pressure rating 64 bar
Compact IP65 design
High accuracy and repeatability



EL-PRESS P-602CV (P2-CONTROL)

Min. pressure 5...100 mbar
Max. pressure 3,2...64 bar
Absolute or gauge pressure
High accuracy



EL-FLOW SELECT F-201CV

Min. flow 0,16...8 ml/min
Max. flow 0,5...25 l/min
Pressure rating 64 bar
Compact design
High accuracy and repeatability



E-8000 SERIES

Digital Readout / Control Systems

Bright, wide angle, 1.8" display (TFT technology)
User friendly operation, menu driven with 4 push buttons



BRONKHORST USA INC.

57 South Commerce Way

Suite 120

USA - Bethlehem, PA 18017

Tel. [+1-610-866-6750](tel:+1-610-866-6750)

sales@bronkhorstusa.com