

# DATASHEET IRON REMOVAL FROM WATER BY AERATION A089

---

## APPLICATION NOTE

### Iron removal from water by aeration

#### Using oxygen flow controllers

Raw water that naturally occurs in aquifers in the earth's crust contains dissolved iron. In waterworks that extract and purify water to make it suitable as drinking water, this iron has to be removed to a large extent. Otherwise our drinking water has a metallic taste.

#### Iron removal by aeration

Iron removal usually occurs through aeration of the water, for example using a cascade. Oxygen from the air reacts with the iron ( $\text{Fe}^{2+}$ ) to form solid iron hydroxide flocks that deposit or are removed by filtration. When conventional aeration is not sufficient to remove iron, additional oxygen has to be supplied to the water. Bronkhorst assisted a waterworks company in providing a flow solution for additional oxygen supply.



---

#### Application requirements

To keep the water quality of the waterworks company at a high level, a relatively simple solution had to be provided without the use of any (expensive) chemical compounds. Especially when the contains high concentrations of dissolved iron, conventional aeration - using oxygen from the air - may not be sufficient and pure oxygen supply will provide a better solution.

#### Important topics

- Oxygen gas supply proportional to water flow
- Fast controlling solution
- No other chemicals necessary

## Process solution

The waterworks company has its own techniques to analyse if the raw water flow requires any additional oxygen supply. If so, the flow through a water channel is measured and its signal is forwarded to an E-8000 readout and control unit that transmits the set point value to the splash proof thermal mass flow controller. The oxygen mass flow is proportionally related to the flow in the water channel and has a value in the range of 10 to 133 normal liters of oxygen per minute.

The supplied oxygen is generated by air separation by means of pressure swing adsorption (PSA). An electronic pressure controller is used to set the pressure in a buffer tank prior to the mass flow controller. This device supplies the correct amount of oxygen to the water, about 10 to 133 l<sub>n</sub>/min of O<sub>2</sub> is dosed, free of oil and grease.

Aeration (simply said; adding oxygen to water) is a rather natural way to remove dissolved iron from raw water, without the use of additional chemical compounds.

This technique can also be applied to remove dissolved manganese from raw water to some extent. First the oxidised iron and manganese deposits on a filter and then it is removed from the filter by backwashing.

The configuration as provided here can be a solution for waterworks companies that need additional water aeration, as well as for oxygen producing companies (e.g. by pressure swing adsorption - PSA) that need a controlled way to supply the produced oxygen in a wide range of mass flow or volume flow.

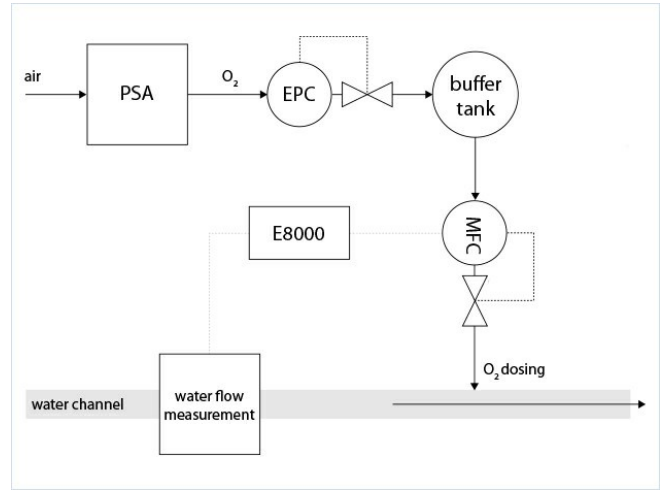

Flow scheme

## Recommended Products



**MASS-STREAM D-6361A/002BI MFC**

Min. flow 0,4...20 l<sub>n</sub>/min  
 Max. flow 4...200 l<sub>n</sub>/min  
 Pressure rating up to 20 bar  
 Rugged sensor and housing (IP65)  
 Optional integrated TFT display



**EL-PRESS P-702CV (P1-CONTROL)**

Min. pressure 20...100 mbar  
 Max. pressure 12,8...64 bar  
 Absolute or gauge pressure  
 High accuracy



**EL-FLOW SELECT F-201CV**

Min. flow 0,16...8 ml<sub>n</sub>/min  
 Max. flow 0,5...25 l<sub>n</sub>/min  
 Pressure rating 64 bar  
 Compact design  
 High accuracy and repeatability



**E-8000 SERIES DIGITAL READOUT / CONTROL SYSTEMS**

### Digital Readout / Control Systems

Bright, wide angle, 1.8" display (TFT technology)  
 User friendly operation, menu driven with 4 push buttons



**BRONKHORST USA LLC**

57 South Commerce Way

Suite 120

USA - Bethlehem, PA 18017

Tel. [+1-610-866-6750](tel:+16108666750)

[sales@bronkhorstusa.com](mailto:sales@bronkhorstusa.com)

