

A098-FP04 - DOSAGE DES ADDITIFS DANS LA FABRICATION DES BONBONS

APPLICATION NOTE A098-FP04

MEASUREMENT OF ADDITIVE SUPPLY IN CANDY MANUFACTURING

To give a piece of candy its own taste, texture and appearance, or to enhance this character, during manufacturing additives such as colourings, flavourings and acids have to be added to a main stream. The latter is a hot, viscous mass that usually consists of water, sugar and glucose syrup.

Within the candy industry, Haas Mondomix is a machine builder who supplies their equipment to confectionery manufacturers. This equipment is being used worldwide. Recently, Bronkhorst Nederland supplied multiple ES-FLOW ultrasonic volume flow meters in order to measure the amount of additives that have been added to the main stream. By using these ultrasonic volume flow meters, the accuracy of measurement has been improved, and so is the quality control of the manufacturing process.



Application requirements

The flows of colouring agent, flavouring agent and acid are coming from three individual reservoirs, and enter the main stream through three separate small pumps. Each of these pumps are controlled by a PLC (programmable logic controller), where the main stream is the master.

By measuring how much of the three additives is added to the main stream, the consumption of these additives has to become more efficient while keeping the quality of the end product - the mixture that eventually becomes a piece of candy - at a constant, high level.

Important topics

- High-quality confectionery products
 - Efficient use of raw materials (colourings, acid and flavourings)
 - Sanitary design, suitable for food applications
-

Process solution

The Bronkhorst solution consists of 3 ES-FLOW ultrasonic flow meters. Each instrument measures the flow of colouring, flavouring and acid. As these fluids are highly concentrated, only small amounts have to be added. These small amounts can be measured with the ultrasonic flow meter, as the measurement range is within 4 to 1500 ml/min with a precision of +/- 1% Rd. The overall performance and user friendly operation of the ES-FLOW instrument are the main reasons for choosing this device.

ES-FLOW flow meters use ultrasound to measure the volume flow rates of liquids. They are constructed in a stainless steel housing, with a display as part of the device for read-out and control. At the back of the display there is a connector for connection to a pump or a control valve, and with PID control on board, a process can be controlled through the display. As usual with Bronkhorst equipment, PROFIBUS, FLOW-BUS or Modbus protocols for digital communication can be used.

Especially natural colourings and flavourings are costly agents, and a controlled and efficient use of these substances will gain a better quality product, and will save on raw materials as well. By using the ultrasonic flow meter, the quality control of the process is improved. In the old days, if something went wrong in the manufacturing process, poor quality was observed by looking at the candy at a rather late stage, resulting in entire batches of candy that had to be defined as 'second choice'. In the new way using the ES-FLOW volume flow meter, poor quality - if any - will be detected in an earlier stage.

Depending on the type of candy to be produced, the amounts and types of colourings, flavourings and acids will vary. For one type of candy - a red wine gum, for example - these amounts have to be constant for the entire batch. However, the setup is sufficiently flexible to be used for another type of candy - take a green wine gum - after rinsing in between. The amounts of additive will be programmed in the PLC.

In the current process, the ultrasonic flow meter is used for measuring, and sends the measurement values to the PLC. Currently, this procedure is standardised within Haas Mondomix, so that ES-FLOW devices are incorporated as standard option in Haas Mondomix equipment for confectionery manufacturing.

- Interested in how ultrasonic waves can help you measuring low flow rates of liquids? Read our [blog](#).

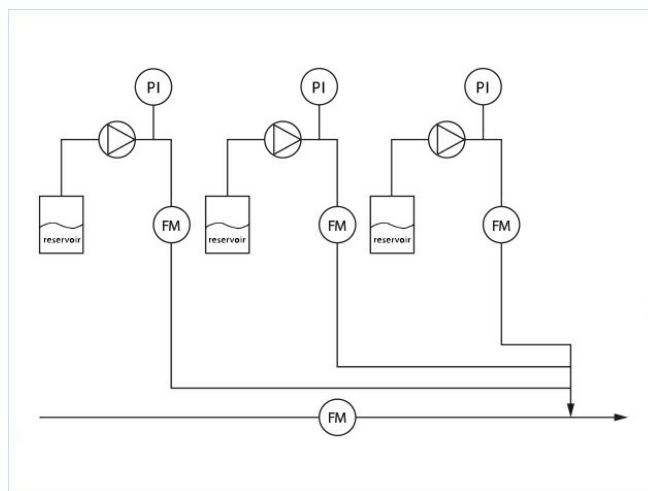

Flow scheme

Recommended Products



ES-FLOW™ ES-1131

Débit min. 4 ... 200 ml/min

Débit max. 1500 ml/min

Pression 100 bar

IP66/IP67, avec écran tactile capacitif



BRONKHORST FRANCE S.A.S.

53 Rue Jacques Verniol

F-95370 Montigny-Les-Cormeilles (FR)

Tel. [+33 1 34 50 87 00](tel:+33134508700)

sales@bronkhorst.fr