

APPLICATION NOTE A086-GP05 - MONITORING OF INDOOR AIR QUALITY

APPLICATION NOTE A086-GP05

MONITORING OF INDOOR AIR QUALITY

Since you spend on average 20 hours each day indoors - in homes, offices, schools or the industrial production environment, just to name a few - a good indoor air quality is very important for your health. In order to keep the indoor air clean, you have to take care of adequate ventilation, and no unnecessary pollutants have to be released.

The French company In'Air Solutions, based in Strasbourg, is specialised in on-site monitoring of air quality and markets a range of high performance pollutant analysers. They have devices for the detection of small amounts of benzene / toluene / ethylbenzene / xylene (BTEX), formaldehyde and (other) volatile organic compounds (VOC) in indoor air. The company got in contact with Bronkhorst France, with the request to help them with gas mass flow solutions for crucial parts of their compact analysers.



Application requirements

As the air analysers themselves are mobile and have to be compact devices, the mass flow controllers and pressure controllers to which they rely on also have to be compact. Furthermore, they have to accurately control flows of air that contain volatile compounds in the ppb range (from 1 to 400 ppb), in order for them to be analysed qualitatively and quantitatively. Moreover, these analysers are mobile and accurate devices and have to perform their duty continuously, in nearly real-time.

Important topics

- High accuracy mass flow controller for low pressure difference applications
 - Compact solution
 - Indoor air quality
 - Reproducibility
-

Process solution

The air quality measurement method of In'Air Solutions consists of a gas-into-liquid take up step in a microfluidic cell combined with a chemical reaction, followed by a detection step using spectroscopy of fluorescence. Here the Bronkhorst chip-sensor based mass flow controllers (MFCs) for gases (series IQ[±]FLOW) - play a key role. Especially in the 'Portable Automatic 4 ways Air Sampler' of In' Air Solutions for volatile organic compounds (VOC) analysis, the low differential pressure version of this [mass flow controller](#) is used.

The compact IQ[±]FLOW instruments allow for the accurate handling of very small gas flows, so that very small quantities of liquid reagents in the microfluidic cell will be necessary, saving on chemicals' consumption allowing low running cost. These small (gas and liquid) mass flows also facilitate the short response time of the analysers, which could be down to the second range. All these features are eminent for compact devices such as those of In'Air Solutions.

As the French government recommends a threshold for formaldehyde concentrations in the indoor air of public buildings of 30 µg/m³ in 2018 and even lower in the years afterwards, accurate and continuous measuring methods are required. The accuracy, sensitivity and reproducibility of the Bronkhorst IQ⁺FLOW devices participate in meeting these demands.

In'Air Solutions is really satisfied with the quality of the Bronkhorst products. In addition to the products themselves, the good support is also emphasised.

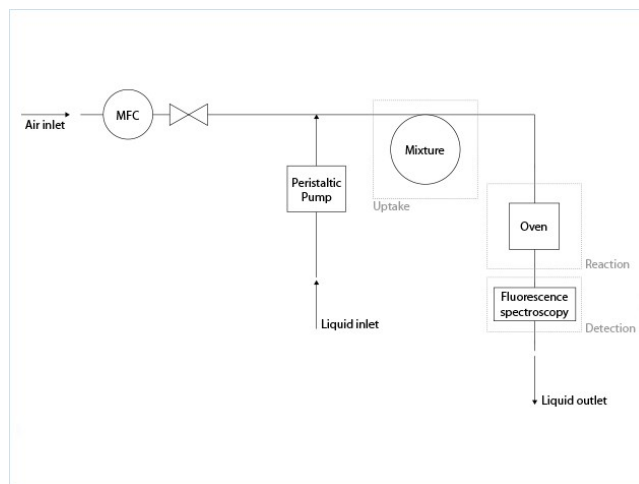

Flow scheme

Recommended Products



IQ+FLOW IQF-200C MFC

Min. flow 0...10 mln/min
Max. flow 0...5 ln/min
Pressure rating 10 bar
Ultra compact
MEMS technology



IQ+FLOW IQFD-200C DOWNPORTED MFC

Min. flow 0...10 mln/min
Max. flow 0...5 ln/min
Pressure rating 10 bar
Ultra compact (MEMS technology)
Top-mount construction



LOW-ΔP-FLOW F-200DV

Min. flow 0,2...10 mln/min
Max. flow 0,4...20 mln/min
Pressure rating up to 10 bar
Low ΔP, easy to purge
Compact design



BRONKHORST HIGH-TECH B.V.

Nijverheidsstraat 1A

NL-7261 AK Ruurlo (NL)

Tel. +31 573 45 88 00

info@bronkhorst.com