

APPLICATION NOTE A079-EN99 - REDUCING EARTHQUAKES WHEN EXPLOITING GEOTHERMAL ENERGY

APPLICATION NOTE A079-EN99

REDUCING EARTHQUAKES WHEN EXPLOITING GEOTHERMAL ENERGY

Geothermal energy seems to be a good replacement for a part of the currently used nuclear energy in Switzerland. The idea itself is quite simple: pump cold water into the earth's crust, allow it to be heated by earth heat, and pump up the hot water to exploit its heat, for example in a power plant. However, there is a catch. In 4-5 km the permeability of the rock is low and need to be enhanced through high pressure fluid injections. This pressure increase can cause induced seismic events.

At the Grimsel Rock Laboratory (owned by NAGRA), ETH Zürich investigates under which conditions such induced earthquakes occur and how the magnitude of such earthquakes can be reduced to be not felt at the earth surface. Bronkhorst mass flow controllers are used in their experiments to simulate the geothermal energy generation process by controlled supply of water flows into the subterranean rocks.



Application requirements

Mass flow controllers are required to accurately inject the desired amounts of water into the rocks, at the right pressure. To investigate which water flow rate will induce a certain activity inside the rocks, the devices should be able to cover a large range of water flow rates. Moreover, due to the fact that the Grimsel Rock Laboratory is located in the middle of the Swiss Alps, it is required to control and monitor the water supply remotely.

Important topics

- Accurate water supply, also at low flow rates
 - Remote control
 - Large flow range with small number of devices
-

Process solution

A series of hydraulic tests such as pulse injection, constant rate, constant head and cyclic water injection are conducted to determine the hydraulic properties of the rock mass and to monitor its influence (i.e. the pressure response) within boreholes in close vicinity to the injection point. As rocks with low permeability are part of the investigation, very small amounts of water at very small rates have to be injected over very long times.

The Bronkhorst solution consists of three different mini CORI-FLOW mass flow controllers mounted on a flow board, and some additional control and monitoring equipment. To investigate the influence of the low flow rate, many different flow rates of pure water have to be used as input parameter, with only a small number of devices. A mini CORI-FLOW M12 flow controller covers a range from 2 to 100 grams of water per hour to be supplied, a mini CORI-FLOW M13 flow controller covers 20 to 1000 g/h, and a mini CORI-FLOW M15 covers 0,8 to 40 kg/h. With the used flow board, each of the three devices can be selected for the appropriate flow rate.

The Bronkhorst Coriolis devices are used here because of their high accuracy, and because they are able to directly supply a certain mass of water regardless of process conditions such as ambient temperature and pressure. Furthermore, water properties such as its temperature and density can be read in real-time. The maximum temperature of the water used at the Grimsel Test Site, which is located at a depth of 400 to 500 meters, is 40°C (only during the thermal tests). This setup is a robust, reliable, flexible, compact and easy-touse way to control the water supply. To track their experiments, the researchers from ETH Zürich use Bronkhorst software, including FlowPlot to make a plot of the entire experiment. Furthermore, they have the possibility using TeamViewer to control, view and monitor the setup at Grimsel from a remote location, so they do not have to be at the Test Site the entire period of time.

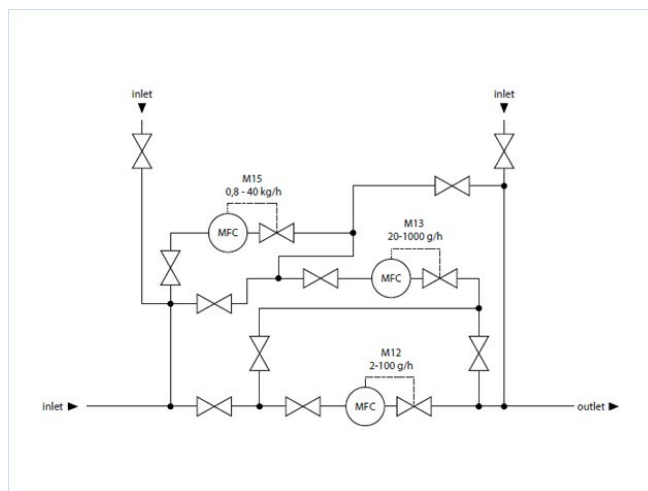

Flow scheme

Recommended Products



MINI CORI-FLOW™ M12V14I

Min. flow 0,1...5 g/h
Max. flow 2...200 g/h
Pressure rating 100 bar
Independent of fluid properties
High accuracy, fast control



MINI CORI-FLOW™ M13V14I

Min. flow 1...50 g/h
Max. flow 20...2000 g/h
Pressure rating 100 bar
Independent of fluid properties
High accuracy, fast control



MINI CORI-FLOW™ M15

Min. flow 0,2...5 kg/h
Max. flow 3...300 kg/h
Pressure rating 100 bar
Independent of fluid properties
High accuracy, fast response



SERIES C2I, C5I

Liquid Flow Valves

Direct acting valve
Pressure rating 64/100 bar
Kv-max: 6.6×10^{-2}



BRONKHORST HIGH-TECH B.V.

Nijverheidsstraat 1A

NL-7261 AK Ruurlo (NL)

Tel. [+31 573 45 88 00](tel:+31573458800)

info@bronkhorst.com