

# APPLICATION NOTE A082-ME09 ACCURATE FLOW CONTROL FOR CANCER RESEARCH

APPLICATION NOTE A082-ME09

## ACCURATE FLOW CONTROL FOR CANCER RESEARCH

**In basic cancer research, a main aim is to unravel differences between normal cells and cancer cells in order to exploit these differences in the hunt for specific cancer vulnerabilities, so that ways can be found to attack cancer cells while leaving normal cells unaffected.**

Since living cells reveal much more information than dead ones, at the Netherlands Cancer Institute (NKI) advanced microscopy techniques are used to extract information about proteins and their interactions in single living cancer cells. To investigate these living cells in their 'natural habitat', Bronkhorst was asked to deliver devices for supplying water vapour and gases such as nitrogen, oxygen and carbon dioxide to mimic the conditions in our body.

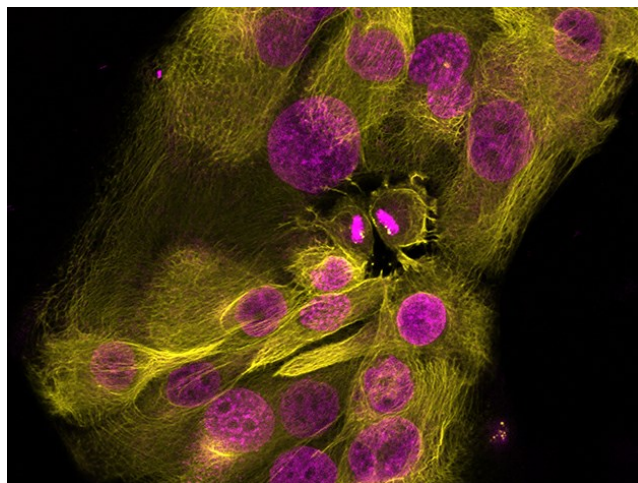

Photo Jalink Group / NKI, Amsterdam

### Application requirements

A dedicated incubator needs to be established that houses the living cells and that 'keeps them alive' under conditions that resemble the various oxygen tensions and other conditions encountered in the human body, while being able to be observed by the microscope.

To this end, the moisturised atmosphere in the incubator needs to be controlled accurately at a temperature of 37 °C, should contain at least 5% CO<sub>2</sub>, and the oxygen content must be adjusted between 2% and 20%.

### Important topics

- Accurate gas flow control for O<sub>2</sub>, N<sub>2</sub> and CO<sub>2</sub>
- Accurate water vapour control
- Low on maintenance

### Process solution

Bronkhorst delivered three [EL-FLOW Select](#) mass flow controllers with read-out units for the controlled supply of air, nitrogen and carbon dioxide gases. By adjusting the relative flows of these gases, an atmosphere was created that contained 2-19 % O<sub>2</sub>, 0-20 % CO<sub>2</sub> and 80-100% N<sub>2</sub>. This range of gases was used in the incubator to investigate the behaviour of cancer cells, for example to investigate how cancer cells migrate during metastasis or to explore how cells use chemical signals to communicate with each other. Investigations at low oxygen content are especially relevant, as solid tumours are well known to be hypoxic - i.e. they contain less than a few % of oxygen - and this completely alters the physiology of the cells, as well as their response to anti-cancer drugs. All experiments conducted under these controlled conditions showed consistent results.

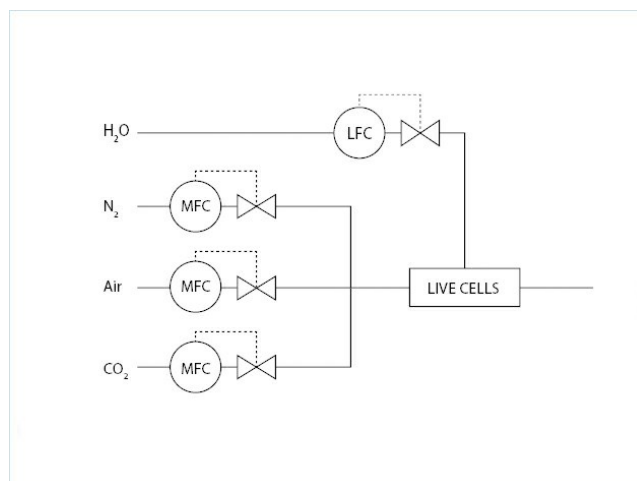

Flow scheme

An artefact of the relatively high operational temperature of 37 °C was that the DMEM medium, a salt solution used for supporting the growth of the living cells, evaporated rather fast. To replenish the evaporated water from the medium, a Bronkhorst μ-FLOW mass flow controller for liquids was used to supply a very stable flow of deionised water. Combined with a local BRIGHT controller with PiPS (Plug-in Power Supply), the μ-FLOW device supplied a controlled water flow between 0.5 and 9.6 microliter per minute.

Empirically, the Netherlands Cancer Institute found that a value of 1.3 μl/min completely compensated for evaporation. Since then, they have been capable of keeping cells alive for weeks while observing them by microscopy. Using this configuration, the relative humidity was kept below 60%, which was necessary to avoid condensation that might damage the sensitive electronics in the setup.

Read more about how flow control can help cancer research:

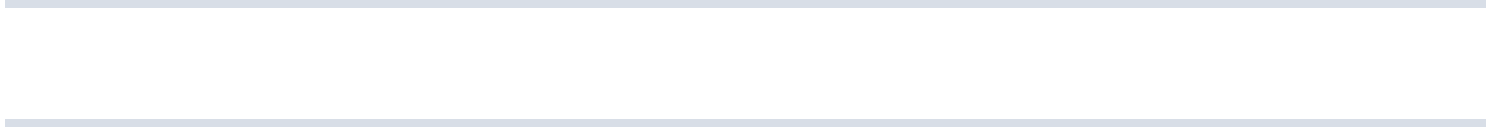

## Recommended Products



**EL-FLOW SELECT F-201CV**

Min. flow 0,16...8 mln/min  
Max. flow 0,5...25 ln/min  
Pressure rating 64 bar  
Compact design  
High accuracy and repeatability



**μ-FLOW L01V12**

Min. flow 5 ... 100 mg/h  
Max. flow 0,1 ... 2 g/h  
Pressure rating 100 bar  
Compact unit; small internal volume  
Analog, RS232 or fieldbus I/O



**BRIGHT SERIES**

### **Compact Local R/C Module**

Bright, wide angle, 1.8" display  
User friendly operation  
Indication/operation/configuration



**PIPS SERIES**

### **Plug-in Power Supply**

For lab-style or industrial devices  
Interchangeable plugs (Euro, UK, USA,  
Australian, IEC) for mains connection



**BRONKHORST HIGH-TECH B.V.**

Nijverheidsstraat 1A

NL-7261 AK Ruurlo (NL)

Tel. +31 573 45 88 00

[info@bronkhorst.com](mailto:info@bronkhorst.com)