

APPLICATION NOTE A075-GP03 ACCURATE DOSING OF RELEASE AGENT

APPLICATION NOTE

ACCURATE DOSING OF RELEASE AGENT

Flow control in the automotive industry

Have you ever seen cars with a nice 'leather look' dashboard? One of our customers in the automotive industry manufactures these 'skins' that look like leather. These 'skins' are produced by spraying liquid - coloured polyurethane - into moulds.

To allow an easy skin release from the mould, a release agent must be applied onto the mould surface. The amount of release agent is essential in this respect and must be **perfectly dosed** as it determines the quality and look & feel of the product. The 'skin' will remain adhered to the mould when too little agent is applied, whereas too much agent will give glossy spots on the skin.

The customer asked Bronkhorst for support in designing a dosing solution which can dose the release agent **very accurate** resulting in **less production loss**. Besides that, the offered dosing solution **reduced** the **downtime** necessary for calibration and maintenance significantly.



Application requirements

In the past, some problems occurred with supplying external release agent using mechanical solutions, such as pressure regulators and gear pumps. These 'old' solutions were not suitable for low flow use and were unstable at low viscosities.

Moreover, their maintenance and calibration costs were high, and the process had to be adjusted continuously by the operator. A new solution to adequately dose external release agent should overcome these problems.

Important topics

- Accurate dosing of release agent
 - Improved process control
 - Visualisation and alarm settings
 - Process data management
-

Process solution

A Bronkhorst Coriolis mass flow controller (series [mini CORI-FLOW M14](#)) combined with a [C5I](#) valve forms the basis of the solution to accurately supply external release agent to the nickel mould surface. These compact devices are mounted next to the robot arm that sprays the agent by means of a spray nozzle. The robot arm moves along the surface of the mould, where the required amount of agent is sprayed homogeneously. This setup is being used for water based as well as solvent-based release agents.

This solution results in a stable flow, even with low flows of less than 5 grams per minute. Compared to the old solutions, the overall release agent application **process stability** has been improved, with respect to the colour and gloss of the manufactured car dashboard skin. Also, reproducibility is high, as the linear flow curves have the same output for all installations. After change of setpoint, the response time is excellent.

Due to the compactness of the Coriolis [mass flow controller](#) and [C5I valve](#), they are easy to install and integrate in existing installations. Data can be transferred from the flow controller by means of RS232, Profibus and analog outputs. [Control & monitoring](#) allow easy visualisation and data capturing.

This solution meets increased quality demands by OEMs, as real mass flows are being measured and controlled. The downtime necessary for calibration and maintenance is largely reduced.

The customer is very pleased with the unequalled results of the solution, as well as with the preceding engineering and cooperation with Bronkhorst. This is demonstrated by the fact that currently, about 100 combinations of flow controller with C5I valve are being used at the automotive factories worldwide.

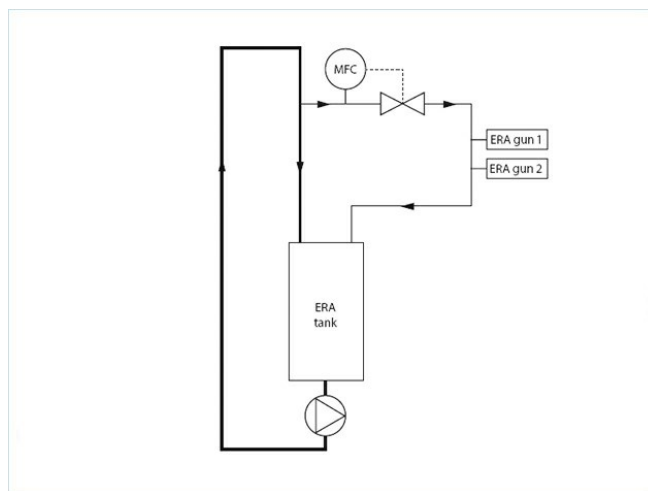

Flow scheme

Recommended Products



MINI CORI-FLOW™ M14

Min. flow 0,03...1 kg/h
Max. flow 0,3...30 kg/h
Pressure rating 200 bar
Independent of fluid properties
High accuracy, fast response



SERIES C2I, C5I

Liquid Flow Valves

Direct acting valve
Pressure rating 64/100 bar
Kv-max: 6.6×10^{-2}



BRONKHORST HIGH-TECH B.V.

Nijverheidsstraat 1A

NL-7261 AK Ruurlo (NL)

Tel. [+31 573 45 88 00](tel:+31573458800)

info@bronkhorst.com