

APPLICATION NOTE A019-OG02 - EXPLOSIVE MIXTURE COMPOSITION

APPLICATION NOTE A019-OG02

EXPLOSIVE MIXTURE COMPOSITION

Accuracy, reliability and safety are requirements for instrumentation used in test equipment for ATEX environments, when gas mixtures of precise composition are necessary.

Instead of buying ready-to-use mixtures, it is cheaper and more simple in logistics, to use self-made mixtures for testing. Instead of 30 bottles with various expensive mixtures supplied by gas manufacturers, only 6 bottles with single gases have to be purchased

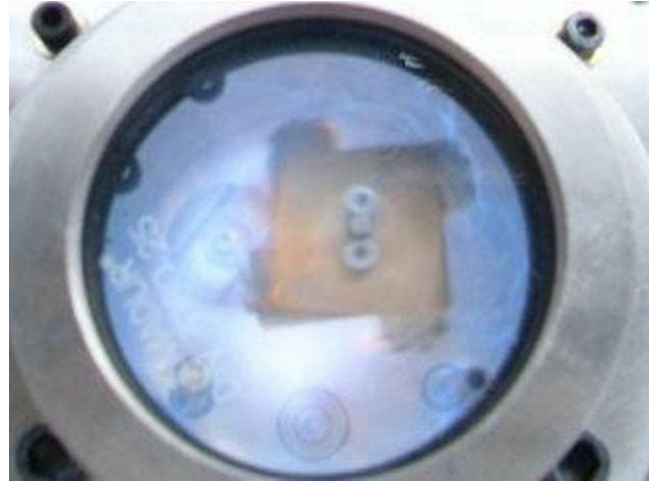

Application requirements

System for Intrinsic safety test including gas delivery and mixing and ignition chamber acc. to BS EN 50020:2002. Explosive mixtures of certain composition has to be delivered to the ignition chamber in a certain time and amount. Each test can be processed automatically or manually. After test completion ignition chamber is automatically purged.

Important topics

- Accuracy of mixtures composition
 - Safety test by explosion
 - Automation of test
-

Process solution

Intrinsic safety test

The intrinsic safety test apparatus consists of ignition chamber with electrodes system and delivery and mixing of gases system. Ethylene, Propane, Methane, Hydrogen, Oxygen and Air are delivered from gas cylinders and mixed on flow. Various explosive mixtures are produced according to BS EN 50020:2002. The mixture of required accuracy is used to fill ignition chamber, which has ignition turntable and electrodes system which can test if circuit under test can cause an explosion. Each test starts with checking ignition ability of mixture and electrodes. The RLC standard circuit have to cause explosion. Thus each test starts with explosion which requires certain safety precaution to avoid explosion in gas supplying lines and flow meters. Some redundant flame arresters are applied as well as check valve.

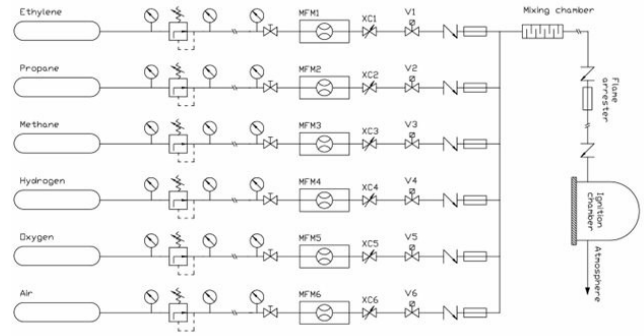

Flow scheme

The gases are delivered by explosion protected mass flow controllers controlled by a readout/control unit and a PLC which controls all the test timing and mixture composition. Some mixtures are pre-installed in the PLC, some other can be programmed by the user.

Recommended Products



EX-FLOW F-201AX

Flow ranges from 0,1...5 l/min up to 2...100 l/min
 Pressure rating 64 bar
 ATEX approval Cat.2, Zone 1
 Rugged IP65 construction



IN-PRESS P-502CI

Min. pressure 2...100 mbar
 Max. pressure 1,28...64 bar
 Absolute or gauge pressure
 Compact IP65 design



IN-FLOW F-201AI

Min. flow 0,4...20 l/min
 Max. flow 0,6...100 l/min
 Pressure rating 64 bar
 Compact IP65 design
 High accuracy and repeatability



BRONKHORST HIGH-TECH B.V.

Nijverheidsstraat 1A

NL-7261 AK Ruurlo (NL)

Tel. +31 573 45 88 00

info@bronkhorst.com