

APPLICATION NOTE A053-GP06 LEAKAGE TEST FOR AIR DUCTS

APPLICATION NOTE A053-GP06

LEAKAGE TEST FOR AIR DUCTS

Air and liquid tightness of devices is of utmost importance. This is especially in the heating, ventilation and air-conditioning (HVAC) sector, where exhaust pipes of central heating systems should not leak combustion gases. And also air ducts installed in buildings, transporting huge amounts of air, have to be airtight to some extent.

To comply with this directive, Bronkhorst has developed a leakage test method. First only for air ducts, later also for exhaust pipes of central heating systems, and also employed for a liquid-tight oil pumps in the automotive sector. This test can be applied to closed systems as well as open systems, temperatures and high pressures, to make the reaction steps as effective as possible and it is related to quality control: more and more ISO certifications require the documentation of quantitative leakage data.

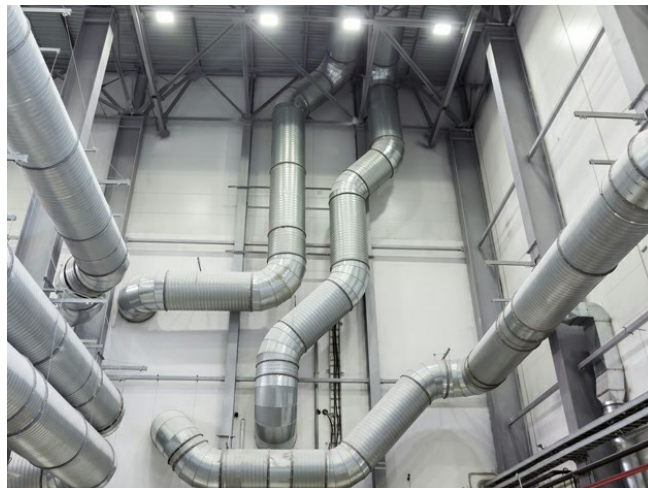

Application requirements

The basic principle is simple: consider a 'device under test', which may be everything, ranging from a small hole to a volume of 10 liters. Apply a pressure by a pressure controller (PC) to that device, and measure any gas leakage using a mass flow meter (MFM). The use of the specific pressure controller and flow meter depends on the setting/measuring range.

Important topics

- Test to check or guarantee leak tightness
- Temperature stabilization

Process solution

A practical realisation of the measuring principle is as follows. Place the device under test (DUT) under a certain gas pressure as specified by the customer, as the leakage rate under that specific condition has to be known. Suppose this initial pressure is 5 bars, then we need to know what incoming flow is necessary to balance the outgoing leakage, in order to keep the pressure stable.

A pressure controller (PC) sets the pressure and the gas flow is measured by a thermal mass flow meter (MFM). Even a liquid-related application can be tested in this way by performing gas flow measurements. In the case of testing air ducts, the gas is pressurised air delivered by the customer's compressor. Normal air can be used, from which water and oil have been removed prior to testing.

However, there are some catches. In order to eliminate the pressure drop over the mass flow meter, the pressure controller needs to be as close to the DUT as possible, so the pressure controller and its valve need to be separated physically. Furthermore, as normally several DUT's are tested in succession, two shut-off valves have to be placed between the setting/measuring equipment and the DUT, to reduce testing time and to improve stability. Moreover, especially for cases with a very small leakage rate, a safe bypass has to be added to the setup in order to fill the DUT quickly. Using such a safe bypass avoids approving a defect product. The solutions to all these 'catches' are shown in the flow scheme.

Temperature stabilisation prior to conducting a measurement is essential. For example, due to gas expansion a temperature variation of 2 °C already results in a volume change of 0.7 %. Any leaks smaller than this volume change cannot be measured when the temperature fluctuates.

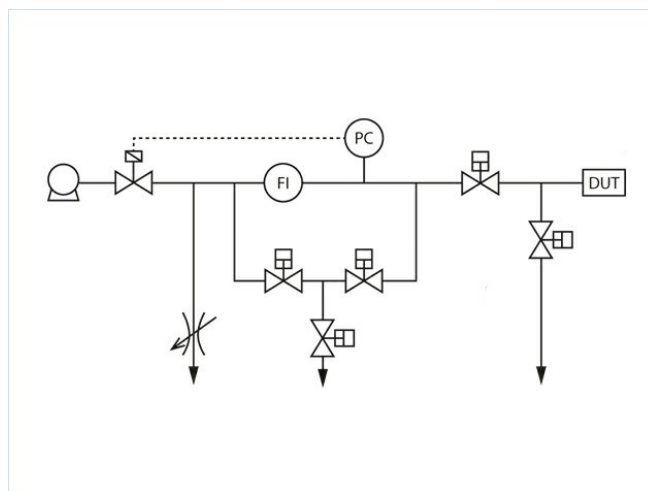

Flow scheme

Recommended Products



EL-FLOW SELECT F-112AC

Min. flow 0,8...40 l/min
Max. flow 1,4...250 l/min
Pressure rating 100 bar
Compact design
High accuracy



MASS-STREAM D-6360 MFM

Min. flow 0,4...20 l/min
Max. flow 2...200 l/min
Pressure rating up to 20 bar
Rugged sensor and housing (IP65)
Optional integrated TFT display



EL-PRESS P-702CV (P1-CONTROL)

Min. pressure 20...100 mbar
Max. pressure 12,8...64 bar
Absolute or gauge pressure
High accuracy



E-8000 - DIGITAL READOUT / CONTROL SYSTEMS

Bright, wide angle, 1.8" display (TFT technology)
User friendly operation, menu driven with 4 push buttons



BRONKHORST HIGH-TECH B.V.

Nijverheidsstraat 1A

NL-7261 AK Ruurlo (NL)

Tel. [+31 573 45 88 00](tel:+31573458800)

info@bronkhorst.com