

# APPLICATION NOTE A107-GP99 - FLOW CONTROL IN VALVE TESTING

APPLICATION NOTE A107-GP99

## FLOW CONTROL IN VALVE TESTING FOR COFFEE MACHINES

**Making coffee, an everyday action for many people, has a technical background. In fact, it is an extraction process where hot water releases aromatics and flavourings from powdered coffee beans by dissolving these compounds. The coffee filter is used to retain the coffee bean parts that are not solved, and you can drink the dissolved compounds as a cup of fragrant hot beverage.**

An essential part of modern coffee machines is the control valve that supplies hot water to the coffee powder - be it inside a capsule or as 'real' powder. [Wandfluh Produktions AG](#) is a manufacturer of these valves, and as such a supplier to coffee machine manufacturers. Originally, as part of the quality control for the valve manufacturing, the company tested their control valves with water. However, these measurements appeared to be too inaccurate. A manual test setup using air and a mechanical valve solved this issue, but they would like to have this setup to be automated. Therefore, the company requested the help of Bronkhorst.



### Application requirements

To test the performance of their control valves, the customer requested a continuous and preferably maintenance-free control of a low air flow in a pressure range up to 20 bars.

### Important topics

- Automated system for constant air supply with low flow rate
- Solution at short notice
- Process-safe setup

### Process solution

A Bronkhorst [EL-FLOW Select mass flow controller](#) with a typical air mass flow of a few litres per minute did the trick. The flow controller was successfully able to supply the desired low air flow at a high pressure range continuously. As part of the solution, the [mass flow controller](#) was connected to the customer's PLC using the RS-232 communication protocol, to control the air supply in an automated way.

Shortly after Wandfluh informed Bronkhorst about their urgent problem, a sales representative went to the Wandfluh site with a demo mass flow controller, with the approximate flow rate that they requested. A test was conducted on-site with good result - the only remark was that the air flow rate was a little too high. By buying a device with a slightly lower flow rate, they had the ideal solution for their problem.

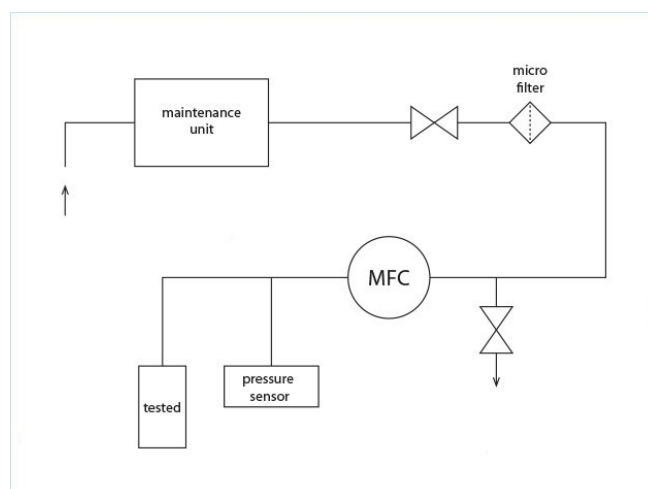

Flow scheme

In the previous manual air supply solution using a mechanical valve, it was difficult to control an accurate air flow. Moreover, no constant air flow could be obtained in case of temperature fluctuations. Replacing the mechanical valve by Bronkhorst's thermal mass flow controller solved both issues.

The use of the Bronkhorst device improved the quality of the valve testing, and made the plant process-safe. In the current setup, Wandfluh now really knows that a 'wrong' valve is indeed a 'wrong' valve, so there are no more false rejections.

---

## Recommended Products



**EL-FLOW SELECT F-201AV**

Min. flow 0,4...20 l/min  
Max. flow 0,6...100 l/min  
Pressure rating 64 bar  
Compact design  
High accuracy and repeatability



**EL-FLOW SELECT F-211AV**

Min. flow 0,4...20 l/min  
Max. flow 2...100 l/min  
Pressure rating 100 bar  
Compact design  
High accuracy and repeatability



**BRONKHORST HIGH-TECH B.V.**

Nijverheidsstraat 1A  
NL-7261 AK Ruurlo (NL)  
Tel. [+31 573 45 88 00](tel:+31573458800)  
[info@bronkhorst.com](mailto:info@bronkhorst.com)