

# D-6381-003BI

---

## MASS-STREAM D-6381/003BI MFC

Direct Thermal Mass Flow Controller for Gases, IP65 protected

- Proven direct inline CTA sensor (no bypass)
- Compact, rugged design (IP65, dust and waterproof)
- Less sensitivity to humidity or dirt
- Optional with integrated TFT display
- Very good price-performance ratio



---

### IP65 Mass Flow Controllers for high flow rates of gases

Bronkhorst® model D-6381/003BI Mass Flow Controllers (MFCs) are suited for precise measurement of flow ranges between 10...500 l/min and 100...5000 l/min at operating pressures between vacuum and 10 bar (Aluminium) or 20 bar (Stainless Steel). The MFC consists of a proven inline thermal (CTA) mass flow sensor, a precise pilot-operated control valve and a microprocessor based pc-board with signal and fieldbus conversion. As a function of a setpoint value, the flow controller swiftly adjusts the desired flow rate. The instrument is IP65 compliant and can optionally be equipped with a modern, multi-functional and multi-colour display, with operator buttons on the instrument.

The digital MASS-STREAM™ series is characterized by a high degree of signal integrity and, as an option, up to 8 calibration curves of different gases and process conditions can be memorized in the instrument. In addition to the standard RS232 output the instruments also offer analog I/O. As an option, an on-board interface can be mounted to provide DeviceNet™, PROFIBUS DP, Modbus-RTU or FLOW-BUS protocols.

---

### Technical specifications

## Measurement / control system

Flow range, based on N <sub>2</sub> (intermediate ranges available)	min. 10...500 I <sub>n</sub> /min max. 100...5000 I <sub>n</sub> /min
Accuracy	± 1.0% RD plus ± 0.5% FS (at calibration conditions)
Repeatability	< 0,2% FS
Turndown	1:50
Type of gases	almost all gases, compatible with chosen materials
Response time sensor	approx. 0,9 sec.
Settling time (controller)	plus approx. 2 seconds
Operating temperature	0...50°C
Temperature sensitivity	±0.2% Rd/°C (Air)
Pressure sensitivity	±0,3% Rd/bar typical (Air)
Control stability	< 0,2% FS typical
Kv-value	max. 6,8
ΔP max	up to 20 bar d
Leak integrity	tested < 2 x 10 <sup>-8</sup> mbar l/s He
Attitude sensitivity	at 90° deviation from horizontal max. error 0,2 % at 1 bar typical N <sub>2</sub>
Warm-up time	30 min. for optimum accuracy, within 30 seconds for accuracy ±4% FS

## Mechanical parts

Sensor	Stainless steel SS 316 (AISI 316L)
Instrument body	Aluminium AL 50ST/51ST (anodised) or stainless steel SS 316
Seals	standard: Viton <sup>®</sup> ; options: EPDM, Kalrez <sup>®</sup> (FFKM), FDA and USP Class VI approved compounds
Sieves and rings	Teflon or stainless steel SS 316
Pressure rating	10 bar g for instrument body in aluminium, 20 bar g for instrument body in stainless steel SS 316
Process connections	G1" / compression type couplings
Ingress protection (housing, optional display)	IP65

## Electrical properties

Power supply	+15...24 Vdc ±10%
Current peak values Meter	approx. 75 mA at 0% flow approx. 125 mA at 100% flow
Current peak values Controller	add 250 mA add 30 mA for display, if applicable add 50 mA for additional interface, if applicable
Analog output/command	0...5 (10) Vdc or 0 (4)...20 mA (sourcing output)
Digital communication	standard: RS232 options: PROFIBUS DP, DeviceNet™, Modbus-RTU, FLOW-BUS

## Electrical connection

Analog/RS232	8 DIN (male);
PROFIBUS DP	bus: 5-pin M12 (female); power: 8 DIN (male)
Devicenet™	5-pin M12 (male)
Modbus-RTU/FLOW-BUS	5-pin M12 (male)

Technical specifications and dimensions subject to change without notice.

For dimensional drawings and hook-up diagrams please visit the [productpage](#) on our [website](#)

## Recommended accessories



### PIPS - PLUG-IN POWER SUPPLY

For lab-style or industrial devices  
Interchangeable plugs (Euro, UK, USA,  
Australian, IEC) for mains connection

## Related products



**MASS-STREAM D-6361/002BI MFC**

Min. flow 0,4...20 l/min  
Max. flow 4...200 l/min  
Pressure rating up to 20 bar  
Rugged sensor and housing (IP65)  
Optional integrated TFT display



**MASS-STREAM D-6383/BJ-1" MFC**

Min. flow 17...500 l/min  
Max. flow 167...5000 l/min  
Pressure rating up to 16 bar  
Rugged sensor and housing (IP65)  
Optional integrated TFT display



**MASS-STREAM D-6370 MFM**

Min. flow 2...100 l/min  
Max. flow 10...1000 l/min  
Pressure rating up to 20 bar  
Rugged sensor and housing (IP65)  
Optional integrated TFT display

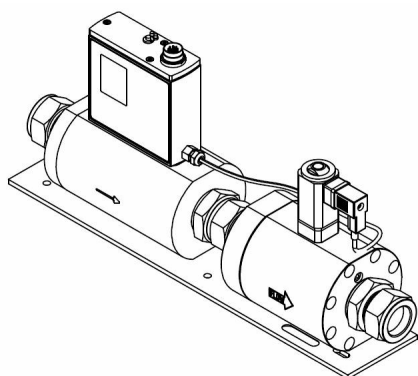

**MASS-STREAM D-6383/003BI MFC**

Min. flow 10...500 l/min  
Max. flow 100...5000 l/min  
Pressure rating up to 20 bar  
Rugged sensor and housing (IP65)  
Optional integrated TFT display



**BRONKHORST HIGH-TECH B.V.**

Nijverheidsstraat 1A

NL-7261 AK Ruurlo (NL)

Tel. +31 573 45 88 00

[info@bronkhorst.com](mailto:info@bronkhorst.com)