

A100-FP03 - GASMISCHSYSTEM ZUR KALIBRIERUNG DES SAUERSTOFFSENSORS FÜR BIERQUALITÄT

APPLICATION NOTE A100-FP03

GAS MIXING SETUP TO CALIBRATE OXYGEN SENSOR FOR MONITORING BEER QUALITY

As most end users of the carbonated alcoholic beverage might know, water, barley, hops and yeast are the main ingredients for making beer. In the beer brewing process, air is supplied to the fermentation step for the reproduction of yeast cells. Nearly all oxygen from the air is used in this fermentation step, and the remaining oxygen level in the subsequent steps should be as low as possible to avoid oxidation for obtaining high-quality beer. To ensure the shelf life and the taste of the beer, the oxygen content has to be monitored continuously and accurately during these subsequent steps.

A global leader in high-precision weighing and measuring equipment, manufactures oxygen sensors to measure the remaining amount of oxygen in liquids - such as in beer brewing and other food & beverage related sectors. The Swiss engineering company [Clerici Engineering](#) built a setup to calibrate these oxygen sensors, for which Bronkhorst delivered mass flow controllers.



Beer brewery

Application requirements

In addition to oxygen (O₂), gases as nitrogen (N₂) and carbon dioxide (CO₂) will be present in the beer brewing liquid - either or not dissolved into the liquid. So, to calibrate sensors that have to determine the oxygen level accurately, the influence of these other gases has to be taken into account. For this purpose, a broad range of compositions of these gases (oxygen, nitrogen, carbon dioxide as well as air) has to be generated and supplied to the oxygen sensor.

Important topics

- Accurate mass flow control for gases using thermal flow controllers
 - Process flexibility by applying up to 27 pre-defined gas compositions
 - High flexibility in controlling
-

Process solution

The gas mixing setup as manufactured by Clerici Engineering consists of two compactly built stainless steel boxes - the gas mixing box itself as well as the control box with touch display - that are connected to each other via signal lines. Bronkhorst delivered six thermal mass flow controllers (EL-FLOW Select series) as part of six gas supply lines, with the aim to mix the supplied dry gases (oxygen, nitrogen, carbon dioxide, air) to obtain a certain, desired composition.

Two of the six mass flow controllers have a flow range of 0.06 - 3 l/min, two have a flow range of 0.006 - 0.3 l/min, and two of 0.0006 - 0.03 l/min. Each of these mass flow controllers were calibrated for air with extra curves for oxygen, nitrogen and carbon dioxide. In addition to being able to supply low gas flows very accurately, this is a flexibility feature because less devices can be used for the setup, as each device is able to deal with several gases and flows.

In practical application, the gases are supplied from the gas mains. The gas compositions are set up via the touch display of the control box. The gases enter the gas mixing box, pass the mass flow controllers that are grouped in two groups of three devices for obtaining high accuracy, and are combined in a mixing chamber. Downstream of the mixing chamber and outside the gas mixing box, the to-be-calibrated oxygen sensor is mounted. The duration of the calibration tests is days to weeks. During these tests, characteristic curves are recorded and analysed.

The current setup is a modification of an original gas mixing setup. Originally, the setup consisted of four lines, and the improvement of the two extra lines is that it gives more accuracy (better resolution, up to three digits after the decimal point) and more flexibility (more mixing options). With respect to the six vs. four lines system, no additional other gases are supplied, but there are different ranges of the flow rate. This means that a higher accuracy can be obtained in a typical (lower or higher) flow range.

In addition to a high level of accuracy, the calibration setup is flexible in the sense that up to 27 different gas compositions can be programmed. The Siemens programmable logic controller (PLC) inside the control box is operated via touch screen to generate the gas mixtures. As some of these compositions have already been programmed in the PLC, the client can simply press one button and start with calibrating using the first gas composition.

The Profibus protocol for (data) communication enhances the flexible control of all instruments together in the setup, making it easy to use. Profibus also allows readout of temperature and other parameters such as setpoint values and measuring values of the flows. Furthermore, measuring data are transferred by USB from the Siemens PLC to the client's personal computer, to log, track and analyse these data using Excel.

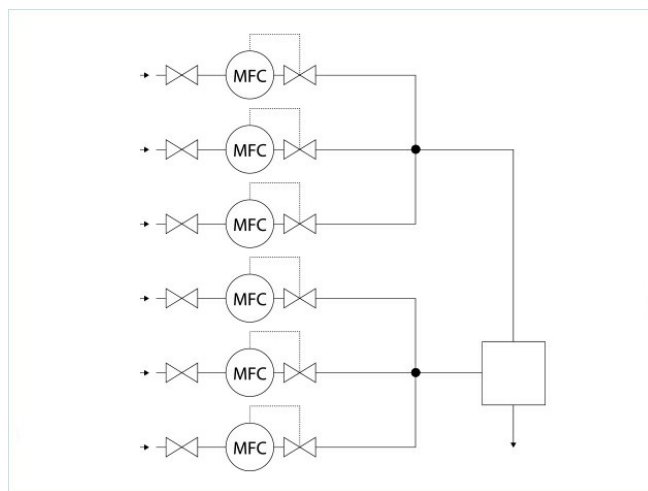

Flow scheme

Recommended Products



EL-FLOW SELECT F-201CV

Min. Bereich 0,16...8 mln/min

Max. Bereich 0,5...25 l/min

Druckstufe 64 bar

Kompakte Bauweise

Hohe Genauigkeit

& Wiederholgenauigkeit



BRONKHORST DEUTSCHLAND NORD GMBH

Südfeld 1b

59174 Kamen (GER)

Tel. +49 230792512-0

info@bronkhorst-nord.de

