

BURNER APPLICATIONS - RATIO CONTROL

Burners are usually found in welding, cutting or furnace applications. All these applications require an extremely efficient flame control. Gas flow has got a preponderant role on achieving good characteristics of combustion flame.

Hence optimal flow control is required. Bronkhorst is fully aware of the demands involved and has developed throughout the years unique solutions for burner applications.



Application requirements

For these processes the pressure of the gas is critical. Pressure irregularities may cause the flame to be extinguished or increase the resultant amount of NOx. Usually the mass flow controllers must operate with very low backpressures. Burner manufacturers want customised pre-tested solutions, instruments with digital (bus) communication and easy to start-up. Flame arrestors may be required and can be supplied.

Important topics

- Accurate dosing of exhaust gas constituents
 - Stability
 - Flexibility
-

Process solution

Burner Ratio Control

For every burner application two flow gases are required: the fuel (methane, propane or acetylene) and the oxidant (air or oxygen).

In order to attain an ideal combustion flame and maintain its dynamic behaviour constant, it is crucial to control accurately the ratio between both gases. The necessary stoichiometry of air must be guaranteed, otherwise security may be compromised.

At the same time, and to avoid excessive fuel spendings and to downplay NOx emissions, it should be possible to use the minimum required air amount.

The solution presented can successfully deliver proportional gas flow respecting the necessary stability. As the combustion gas is supplied by a flow controller (Master), the oxidant gas is delivered accordingly in the correct proportion by another flow controller (Slave), in such way successful ratio control is accomplished.

The instruments do have a fast response time which, together with a unique stability guarantees flame's constancy.

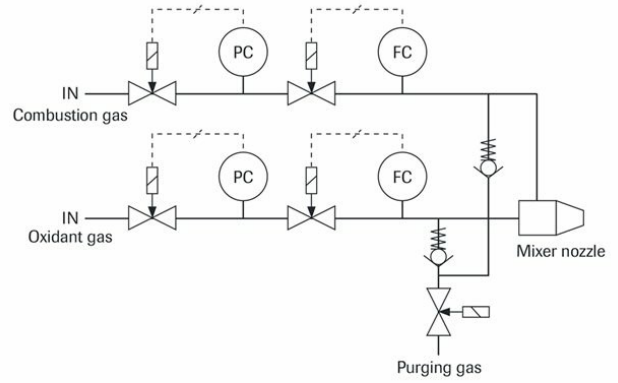

Schematical drawing

Recommended Products



LOW- Δ P-FLOW F-101D

Min. flow 0,42...21 mln/min
Max. flow 0,042...2,1 ln/min
Druk tot 10 bar
Zeer lage drukval
Geschikt voor corrosieve gassen



LOW- Δ P-FLOW F-201EV

Min. flow 0,028...1,4 ln/min
Max. flow 0,24...12 ln/min
Druk tot 10 bar
Lage Δ P, gemakkelijk te spoelen
Compact ontwerp



LOW- Δ P-FLOW F-201ES

Min. flow 0,028...1,4 ln/min
Max. flow 0,24...12 ln/min
Druk tot 10 bar
Lage Δ P, gemakkelijk te spoelen
Geïntegreerde elektrische shut-off



BRONKHORST NEDERLAND

Lunet 10c

3905 NW Veenendaal

Tel. +31 (0)318 55 12 80

info@bronkhorst.nl