

A057 - NAUWKEURIGE DOSERING NITROBENZEEN

APPLICATION NOTE A057-CM02

HIGHLY ACCURATE DOSING OF NITROBENZENE

Nitrobenzene is a pale-yellow coloured organic compound with chemical formula $C_6H_5NO_2$. This liquid compound is mainly used as a precursor for the synthesis of the organic compound aniline, which, in turn, is a precursor for many industrial compounds.

Liquid nitrobenzene needs to be dosed with high accuracy in a chemical pilot plant in order to generate an optimised chemical end product. Before Bronkhorst became involved, the liquid was manually dosed with needle valves. There were however some issues with this procedure. The needle valves were not accurate enough, due to changes in temperature or pressure. The R&D engineers and operators of the pilot plant looked for a better solution, and arrived at Bronkhorst. After observing the [mini CORI-FLOW](#) demo case with flow software included, they decided to build a new dosing system with Bronkhorst equipment incorporated.



Application requirements

The reproducibility of the dosing solution for nitrobenzene should be better than $\pm 0.5\%$ of the reading. Furthermore, the dosing solution should compensate for variations in the process upstream of this solution, in order to obtain a stable flow of nitrobenzene.

Important topics

- Highly accurate and reproducible
 - Compensating for varying process conditions
 - Stability in dosing
-

Process solution

The new nitrobenzene dosing system comprises a Tuthill gear pump, a degassing valve, three Coriolis mass flow controllers (M13 mini CORI-FLOW series) with filters and some additional equipment. The degassing valve between the gear pump and the mass flow controllers is necessary to tackle the problem of gas bubbles in the nitrobenzene liquid.

After successfully implementing this new dosing system, a repeatability of the measurement value for each (M13) mass flow controller of $\pm 0.1\%$ of the reading has been obtained, well within the requirements. The pilot plant engineers and operators are highly satisfied with this solution.

However, prior to a successful implementation of the Coriolis mass flow controller, some conditions had to be fulfilled. At first, a vibration dampener has to be mounted below the mass blocks of each flow controller. Without such a dampener, an incorrect zero point is obtained. In addition to that these mass blocks were heated, to eliminate potential inaccuracies caused by temperature fluctuations. Furthermore, the pipe between the gear pump and the flow controllers has to be relatively short and straight. Too long, tortuous and too narrow pipes will result in pulsation and gas bubbles in the mini CORI-FLOW mass flow controllers.

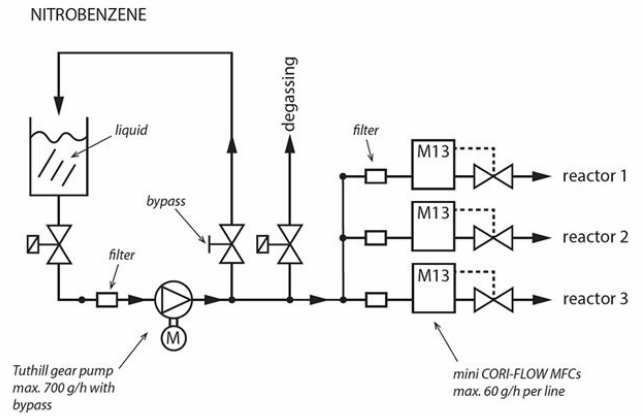

Flow scheme

Recommended products



MINI CORI-FLOW™ M13V14I

Min. flow 1...50 g/h
Max. flow 20...2000 g/h
Drukklass 100 bar
Vloeistof onafhankelijk
Hoge nauwkeurigheid, snelle regeling



MINI CORI-FLOW™ ML120V00

Min. flow 0,05...5 g/h
Max. flow 2...200 g/h
Drukklass 200 bar
Onafhankelijk van
vloeistofeigenschappen
Hoge nauwkeurigheid



MINI CORI-FLOW™ M15

Min. flow 0,2...5 kg/h
Max. flow 3...300 kg/h
Drukklass 100 bar
Onafhankelijk van
vloeistofeigenschappen
Hoge nauwkeurigheid



BRONKHORST NEDERLAND

Lunet 10c

3905 NW Veenendaal

Tel. +31 (0)318 55 12 80

info@bronkhorst.nl